

# INSTRUCTIONS FOR USE

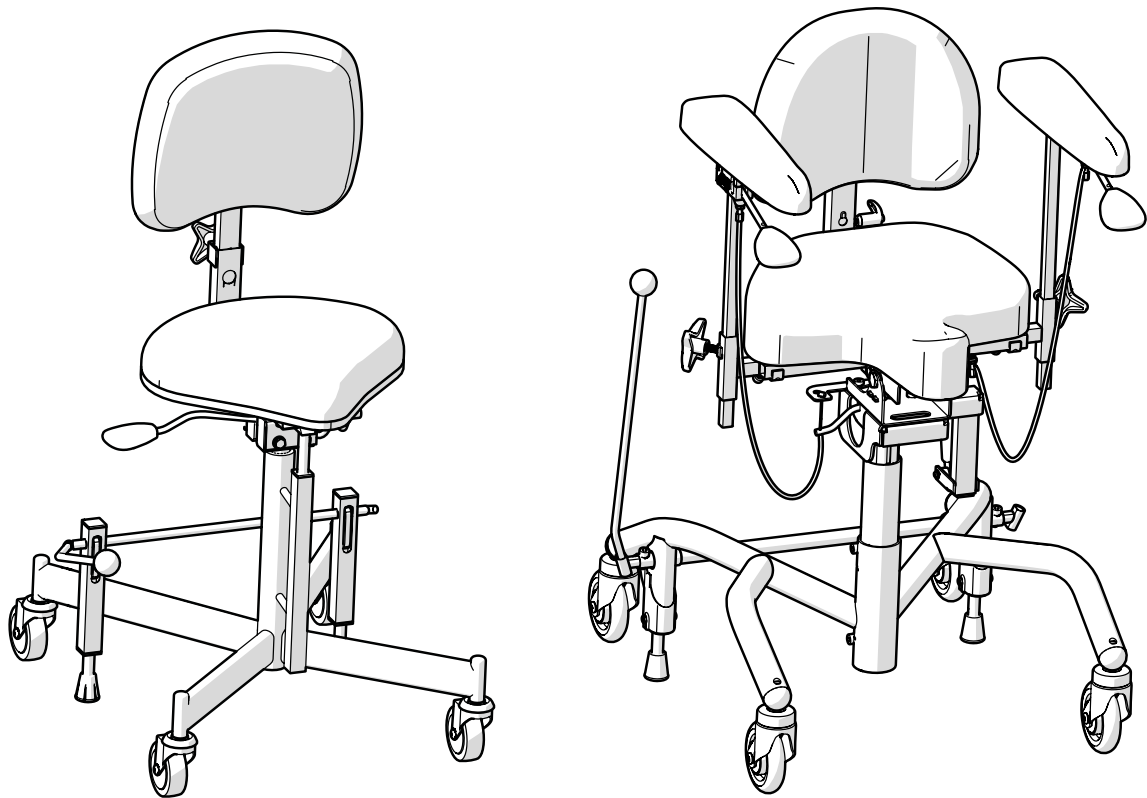

for medical standing support and chest support chairs EN  
in the REAL 2000 series, as well as the  
REAL 9500 PLUS and REAL 9600 PLUS EL 24V series  
Instructions for use and care



Translation of manual  
Item number: 21-08907-EN  
Revision: 04  
Valid from: 2021-05-26  
Amended: 2022-04-01



[Space for device label with serial  
number]

# Table of contents

## User information

1. Introduction	4
1.1. Contact details	5
1.2. Warranty	5
2. Getting started	6
2.1. Before use	6
2.2. Electrical and manual height adjustment	9
2.3. Charging	10
2.4. Transfers	11
3. Caring for the device	12
3.1. Padded parts	12
3.2. Castors and brake feet	12
3.3. Other parts	12
3.4. Transport and storage	13

## Device information

4. Intended use	14
4.1. Operating environment	14
5. Configurations and settings	15
5.1. Required level of competence for setting and adjusting	15
5.2. Basic design	16
5.3. Electrical functions	16
5.4. Seat	19
5.5. Manual height adjustment	21
5.6. Manual seat tilt	21
5.7. Backrest	23
5.8. Backrest mechanism	24
5.9. Chest support	25

5.10. Chest support mechanism	26
5.11. Armrest panel	27
5.12. Armrest mechanism	28
5.13. Base	29
5.14. Manual brake	30
5.15. Individual adaptation	32
6. Important safety information	34
6.1. Standards met and classification	34
6.2. Warnings	35
6.3. Expected service life	36
6.4. Reporting of adverse events and incidents	37

## Service manual

7. Technical information	38
7.1. Symbols	40
8. Servicing & reconditioning	43
8.1. Troubleshooting guide	44
8.2. Battery replacement	47
8.3. Reconditioning and periodic maintenance	48
9. Instructions for destruction	54
9.1. Recycling	54

# 1. Introduction

Thank you for choosing Mercado Medic as the supplier of this device. By choosing a REAL chair, you get to learn about a 50-year history of developing medical devices with high function, safety, quality and flexibility. We manufacture all our different medical chairs under our own management in Sweden.

Mercado Medic is certified to ISO 13485, ISO 9001 and ISO 14001, and complies with applicable labour and environmental legislation.

We reserve the right to make changes to this manual and its contents.

Sufficient competence in the safe use of this device is achieved by carefully reading through these instructions for use before using the device for the first time.

PDF versions of our instructions for use with zoom options are always available in their most current version on our website [www.mercado.se](http://www.mercado.se).



**1.1. Contact details**

**Manufacturer**

Street address: Mercado Medic AB,  
Tryffelslingan 14, SE-181 57 Lidingö, Sweden

Postal address: Mercado Medic AB,  
Box 1074, SE-181 22 Lidingö, Sweden  
Telephone: +46 (0)8 555 143 00  
Email: [info@mercado.se](mailto:info@mercado.se)  
Website: [www.mercado.se](http://www.mercado.se)

**Servicing and technical support**

Telephone: +46 (0)8 555 143 08  
Email: [service@mercado.se](mailto:service@mercado.se)

To report warranty claims, adverse events and incidents or other feedback please use the form at [www.mercado.se/en/support/](http://www.mercado.se/en/support/).

**Distributor**

Space for additional distributor contact details:

-----  
-----  
-----  
-----

**1.2. Warranty**

All components of Mercado Medic's devices are covered by warranty, under the time periods and general terms and conditions set out below, unless other specific periods and conditions are agreed in writing between Mercado Medic and the contracting customer in connection with major procurements.

As a user, you should contact your prescriber, assistive technology centre or distributor if you experience problems with the device. Distributors in turn should contact Mercado Medic using the contact details available under Section 1.1. Contact details.

**Warranty periods**

- Metal structures: 3 years.
- Lifting mechanism (electric and gas spring): 2 years.
- Other components (e.g. wheels, batteries, padded parts): 1 year.

**General terms and conditions**

The warranty does not cover:

- Damage or condition considered to be normal wear and tear.
- Damage caused by negligence or misuse.
- Spare parts, components or accessories not sold by Mercado Medic.
- Adjustments to the device made by unauthorised service technicians.
- Components previously fitted to devices other than the item in question.
- Bleaching or natural variations in the colours of fabrics, synthetic leather and natural leather.

## 2. Getting started

This section is primarily aimed at you as a user of the device. It describes how to prepare the device for use, adjust the seat height, charge electric models, and how to create good conditions when moving. For care instructions, see 3. Caring for the device.

If you have any questions about your device or if something unexpected has happened, please first contact your prescriber or dealer. You can find up-to-date contact details in Section 1.1. Contact details. You are also welcome to contact us at Mercado Medic.

### 2.1. Before use

All devices come with a seat, back support or chest support and a brake. Upon delivery from Mercado Medic, the back support, chest support and brake lever are unattached. These should always be fitted before the device is first used.

#### Brake lever

For models with a brake lever, insert the brake lever into brake-lever bracket (A) (see Figure 2.1). The brake lever can be placed on the right or left side. For models with a foot brake, no installation is necessary.

#### Backrest mechanism

For models with back support, insert the backrest pole into the backrest mechanism (B) and adjust to the desired height (see Figure 2.1). Tighten all controls (B). The image shows one of several back mechanisms available for Mercado Medic devices. Other back mechanisms are mounted in the same way, although the appearance may differ from that in the image.

#### Chest support mechanism

For models with chest support, insert the chest-support pole into the chest support mechanism (C) and adjust to the desired height (see Figure 2.2). Tighten all controls (C).

#### Armrests

For models with armrests, loosen the armrest control (D) and adjust to the desired height and width (see Figure 2.1). Tighten all controls (D).

#### Battery

Before first use, the battery in electric models must be activated and/or charged. This is done by connecting the battery charger to the device's charging outlet and to a wall outlet (E), see Figure 2.1. The charging outlet can be placed in different places on the device. The most common is that the device comes with the charging outlet mounted at the rear edge of the left armrest.

Wait until the battery is fully charged before using the device. This normally takes 2 to 5 hours. When the battery is fully charged, the LED on the charger lights up green. For other charging instructions, see 2.3. Charging.

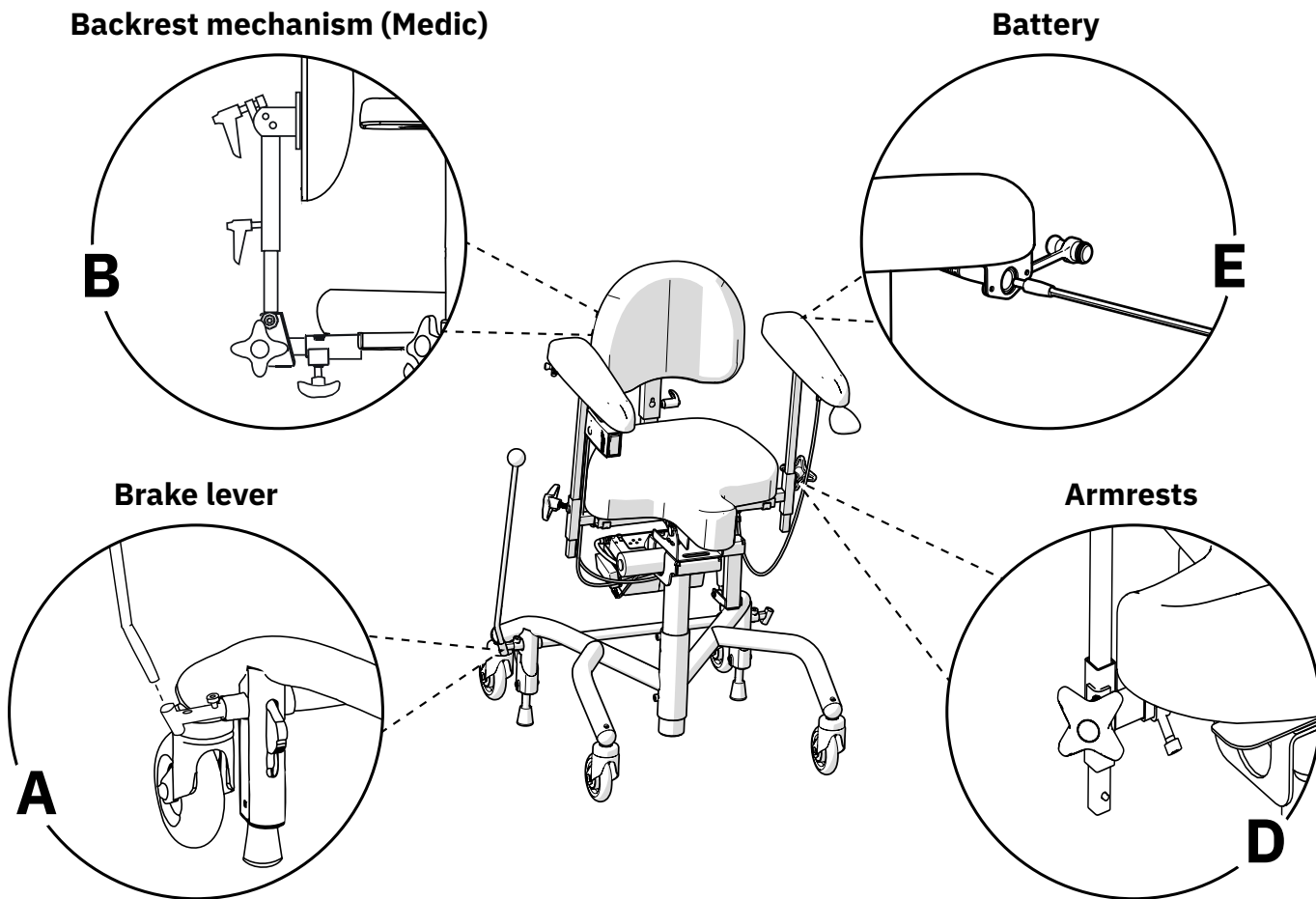

Figure 2.1. Preparations before starting to use models with back support.

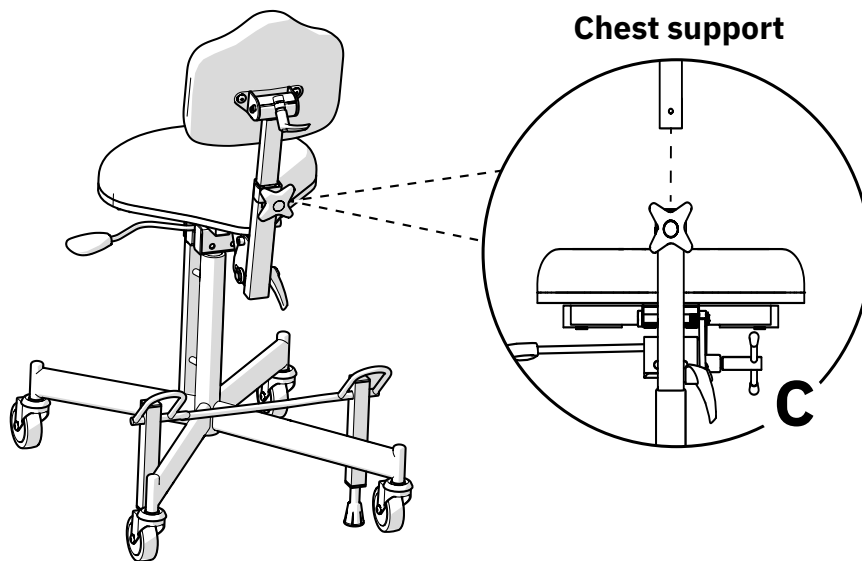

Figure 2.2. Preparations before starting to use models with chest support.

### Consider the following before and during use of the device

- All settings controls should be tightened before using the device.
- The device must not be used without fitting the backrest.
- The device must not be used without fitting the armrests.
- The device's brake must always be applied when sitting down and getting up.
- The braking capacity of the device may be impaired on heavily sloping floors.
- The braking capacity of the device may be impaired on uneven floors.
- The device must be operated with care. Always be aware of your surroundings before moving. Pets or children on the floor could be easily hit.
- The optional foot support ring is designed to rest your feet on, not to stand on.

For models with electrical functions,

- Charge the device according to these instructions for use, see Charging.
- The electrical functions cannot be used when the device is charging.
- If the device is equipped with leg support, your feet should always be in contact with the footplate when using the electrical functions.
- The seat must never be set to a height where you are unable to get out of the device safely.
- The device must not be moved when the seat is in the raised position.
- Emergency stop for control buttons: If, for whatever reason, the system does not interrupt a movement after the corresponding control button has been released, the movement can be interrupted by pressing the button for movement in another direction.

- Emergency stop for hand-held controller: If, for whatever reason, the system does not interrupt a movement after the corresponding control button has been released, the movement can be interrupted by pressing any of the other buttons on the hand-held controller.
- Button lock on hand-held controller: To enable or disable the button lock for a function, press and hold both of the directional buttons of the relevant function for at least three seconds. The button lock locks only the current function. To lock multiple functions, each function must be locked separately.



Warning! As a user, you should contact your prescriber, technical aids centre or distributor if the device shows reduced or altered performance. A device showing a loss of or change in performance must immediately be taken out of use in order to avoid an accident. The device must not be used again until an authorised technician has examined the device.



Warning! To maintain safety, the device should only be used by the person and purpose for which it is intended. The device is set up for a single user. Changing settings may affect the user's seating position, which may result in damage or injury.



Warning! You are not permitted to modify the device yourself. If you would like individual customisation, contact your prescriber or distributor. If the device is modified, the CE marking no longer applies and Mercado Medic may no longer have full device liability. Modifications may affect the safety of the device and lead to accidents.



Warning! The device may be equipped with long cables or wires that cannot be secured in order for the device to function properly. Cables and wires can pose strangulation risks to small children, for example. Do not leave the device unattended with small children nearby.



Warning! The device is equipped with small parts such as screws that can come loose. Small parts that have come loose can pose choking hazards for children and pets.



Warning! Metal surfaces may become very hot if they are exposed to direct sunlight. Skin contact with hot surfaces can lead to burns. Avoid exposing metal surfaces to direct sunlight.



Warning! Always ensure that the device's brake is applied when sitting down and getting up. If the device is not braked, it risks rolling away when you get up or sit down, which can lead to fall injuries.

## 2.2. Electrical and manual height adjustment

Depending on the model, the device has electric or manual height adjustment. To adjust the height electrically, use the hand control or button placed under the right armrest (see Figure 2.3). To adjust the height manually, use the control placed under the seat or under the right armrest (see Figure 2.4). See 5. Configurations and settings for detailed information about all the features and controls of the device.

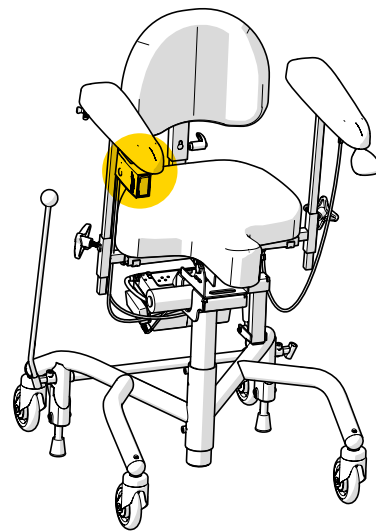

Figure 2.3. Controls on the electric model.

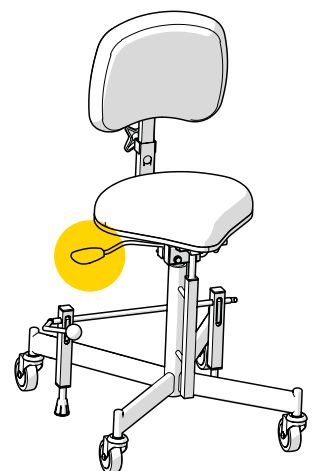
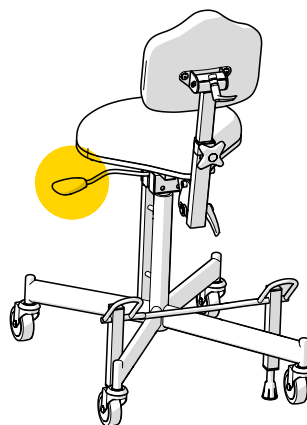
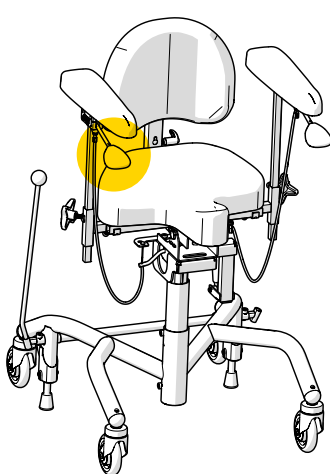

Figure 2.4. Controls on manual models.

### 2.3. Charging

For electric models, the battery should be charged once a day. Fully charging the battery on a daily basis will take 2 to 5 hours. It is important that the battery is never completely discharged, as this helps to prolong the life of the battery. Daily charging of the battery is especially important on the configurations with electric brake, electric seat tilt and electric back rest mechanism, to ensure that you as a user can always get in and out of the device safely. The device must be charged in a safe manner. The electrical functions cannot be used when the device is charging. For this reason, choose an easily accessible wall socket to plug the charger into. The charger cable to the wall socket is 1 metre long and must not be extended. In case of emergency, disconnect the device from the mains by unplugging the charger from the wall socket.

Products fitted with the RCB10+L control system will emit a low battery level audio signals, for both low and critical. Low battery level is indicated by a short signal. Critical battery level is indicated by a short signal that ends with a loud beep. The product can also indicate low or critical battery levels using a signal when the product's battery is activated after the system has been in sleep mode. This is because when starting up, the product has not yet determined its charge level. This signal stops after two minutes. If the device is equipped with hand control, the battery level can also be read on the indicator lights (see Figure 2.5).



Figure 2.5. Battery level indicator on hand-held controller.

#### How to charge the device

1. Inset the plug into the charging outlet (see Figure 2.6). The charging socket is normally located at the rear edge of the left armrest, but can also be located under the seat, for example.
2. Connect the charger plug into the wall socket. The LED on the charger will indicate that charging is underway.
3. The battery is fully charged when the LED on the charger changes colour from red to green. If you are using the hand-held controller, this will also be indicated by the three green battery LEDs on the controller, which will start to flash at the same time.

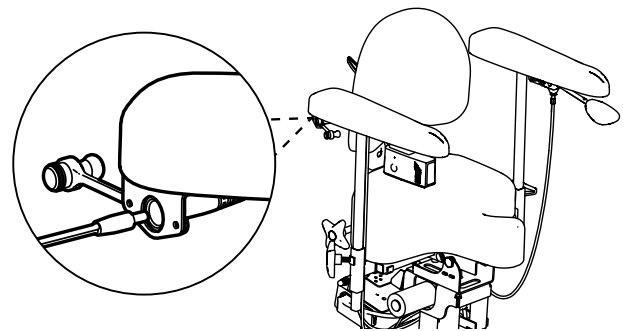

Figure 2.6. Connecting the plug to the charging socket under the armrest.

For those products fitted with the RCB10+L control system, the battery will be automatically disconnected if the electrical functions have not been used for 7 days. To reconnect the battery, connect the battery charger to the charging outlet and the wall outlet and wait at least 5 seconds before unplugging the charger. It is recommended to charge the battery fully after the battery has been disconnected.

If no electrical functions are working, try charging the battery. If electrical functions still do not work, contact your prescriber or distributor, see 1.1. Contact details.

## 2.4. Transfers

When moving around while sitting in the device, it is important to make good contact with the floor. For example, rubber-soled indoor shoes can provide better grip and thus facilitate movement. Rugs and carpets make the movement more difficult. It is therefore recommended to remove rugs or carpets if you want to move while sitting.

For negotiating thresholds using the REAL 9500 PLUS and REAL 9600 PLUS EL 24V models, you will get more power by backing over thresholds, mouldings and gaps. Lower the seat and, if possible, adjust the seat tilt forward slightly to get over the threshold.

Do not remain seated on the REAL 2015 or REAL 2624 models when negotiating thresholds, mouldings or gaps.

To find your device's model number, see the label on the device base or section 5.2 Basic model.



**Warning!** Always ensure that the device's brake is applied when sitting down and getting up. If the device is not braked, it risks rolling away when you get up or sit down, which can lead to fall injuries.

## 3. Caring for the device

Clean the device in accordance with the instructions in this section in order to maintain functions and service life. If you still have issues that cannot be resolved using available home resources, please contact your prescriber or distributor for reconditioning.

PLEASE NOTE! Do not wash the device with water or other liquids and chemicals.

### 3.1. Padded parts

To maintain good device hygiene, the device’s padded parts should be cleaned regularly. If padded parts are not regularly cleaned, the device may require reconditioning.

#### Plush padded parts

Use a foam cleaner to clean plush padded parts. Start by removing any loose debris. Then use a cloth to distribute a thin layer of foam. Wipe with a clean, damp cloth. Finish by vacuuming the upholstery after it has dried.

#### Synthetic leather padded parts

Use soap and water or surface disinfectant to clean synthetic leather padded parts. Start by removing any loose debris. Then use a cloth to clean the upholstery with soap and water or surface disinfectant. If the upholstery is cleaned using soap and water, finish by wiping with a clean, damp cloth.

#### Leather padded parts

Use water to clean leather padded parts. Start by removing any loose debris. Then clean the upholstery with a clean, damp cloth. For best effect, padded parts should be cleaned immediately after something is spilled on it. To extend the service life of padded parts, avoid direct contact with chemicals or prolonged sunlight.

### 3.2. Castors and brake feet

Regular cleaning of castors and brake feet is required to maintain the operation of the device. Wipe castors and brake feet with a damp cloth. Remove any hair from the castors using a thin crochet needle or similar implement.

### 3.3. Other parts

Do not wash or clean the device’s lifting mechanism or other actuators (found by the electric seat tilt and brake, see Figure 3.1). This is because there is a risk that the grease required for these mechanisms to function as intended might be removed during cleaning.

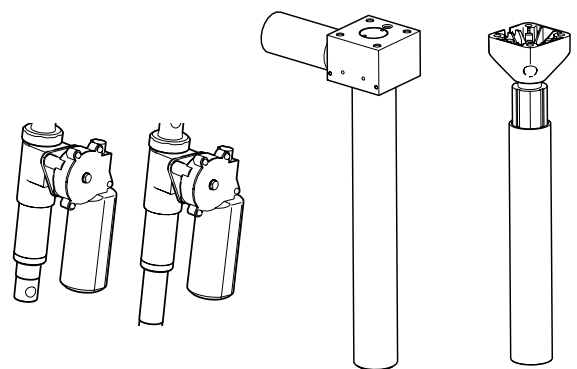

Figure 3.1. device’s lifting mechanism and other actuators.

If necessary, a dry cloth can be used to remove dust from any electronic parts of the device. Clean the other non-electronic parts of the device once a week or when necessary. Use a clean, damp cloth with mild detergent (pH 7-12), surface disinfectant or use a steam cleaner (max. 8 bar).

### 3.4. Transport and storage

When transporting and storing the device, keep the following in mind:

- The device moves by rolling on a flat surface.
- The device should be lifted by two people. Suitable grip points are at the front, rear, right and left sides of the seat, see Figure 3.2.

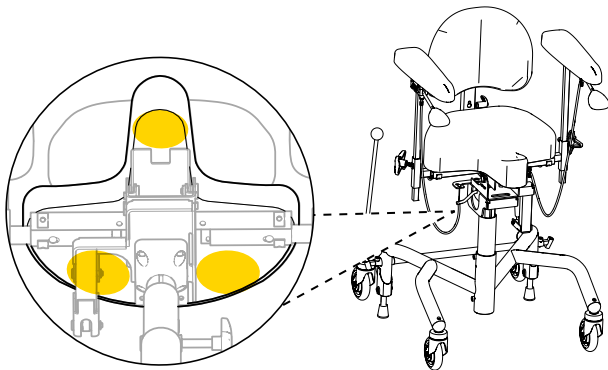
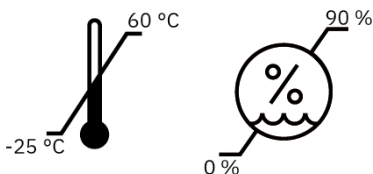

Figure 3.2. Suitable grips when lifting.

- The device must be transported in the intended cardboard box on a pallet. If the device is transported by car, it must be strapped in place using straps over both the base and the seat, and it should be set to the lowest possible seat height. To reduce the size of the device during transport, the backrest can be removed and the armrests lowered. Be sure to select the settings so that they can be easily reset. Tape or similar easily removable marking is recommended.
- The device must not be used as a seat when transported in a car or aircraft, for example.
- In the case of air transport, the device must be stored in the hold. Original Mercado Medic batteries are approved for air transport. For information on battery type, see 7. Technical information.

- The device is intended to be transported and stored at between  $-25^{\circ}\text{C}$  to  $+60^{\circ}\text{C}$  and up to 90% non-condensing relative humidity.



## 4. Intended use

The REAL 2000 product series, as well as REAL 9500 PLUS and REAL 9600 PLUS EL 24V (Mercado Medic's standing support and chest support chairs below) comprise modular activity chairs intended for indoor use by persons requiring assistive devices to manage dynamic activities that are usually done standing up, when moving by their own effort or for standing up from a seated position. The devices are designed to maximise the user's physical ability, which is why they are individually adaptable and come in a wide variety of versions. The devices are also intended for use by people who have problems with pain and people undergoing rehabilitation for working in a forward-leaning position. In these cases, the device is configured with chest support rather than back support. The devices are designed to relieve pressure on lower limbs, muscles, joints and bones and to soothe pain caused by passivity.

Mercado Medic's standing support and chest support chairs are designed and recommended for one or more of the following indications:

- Difficulty or inability to stand up from sitting.
- Difficulty standing up or inability to stand.
- Difficulty or inability to walk.
- Pain or exhaustion arising from everyday tasks at home or at the workplace that are usually done standing up.

### Contraindications

There are no known contraindications for using Mercado Medic's standing support and chest support chairs. If the device is purchased without prescription from qualified healthcare professionals, the user should consult their doctor whether there are any contraindications.

### 4.1. Operating environment

- The device is intended for indoor use only and must not be used outdoors.
- The device is intended to be used at between  $-5^{\circ}\text{C}$  to  $+40^{\circ}\text{C}$  and 15-90% non-condensing relative humidity. If the device is stored in an environment outside these limits, the device must be acclimatised for up to 4 hours to achieve an approved temperature before use.

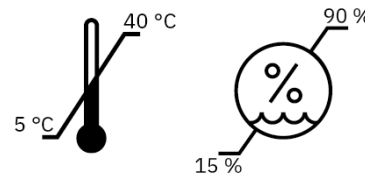

- The device must not be used at altitudes greater than 2000 m above sea level.
- The device must not be exposed to extreme cold or heat, prolonged sunlight or other radiation.
- The device must not be exposed to water, liquids or chemicals to any extent other than that specified in the care information in Section 3. Caring for the device.

## 5. Configurations and settings

This section is primarily aimed at you as a prescriber of the device. It describes the device's models, options when configuring the device, and information about setting and adjusting the device's functions. For dimensions and performance, see 7. Technical information.

The device is available in several configurable models. The basic design of each model is described below, see 5.2. Basic design. In addition to the basic design, there are a large number of options to personalise the device. For available options, see the description for each function in this section. The models can also be equipped as positioning chairs with, for example, torso support, side support and neck support, and further adapted both inside and outside the CE marking, see 5.15. Individual adaptation. For information about accessories and current combination agreements please visit our website [www.mercado.se](http://www.mercado.se). For an overview of accessories, read the document 'Accessories'.

The device is compatible with the upholstery in Mercado Medic's seat system for standing supports, including Classic, Medic and ErgoMedic. The seat system comprises seats, back supports and armrests. The padded parts can be combined as needed for support, relief and stability when sitting. A memory foam version is available for users who have problems with pain. This variant contains a pressure-relieving foam that is activated by body heat. Further details about the seat system and other upholstery are available on our website [www.mercado.se](http://www.mercado.se). For an overview of available upholstered details, read the document 'Ergonomic seat systems for the REAL-chairs'.

On [www.mercado.se](http://www.mercado.se) there are various forms of prescription support such as information sheets, order forms and a digital chair configurator. There are also instructions for use and device information for all Mercado Medic devices.

### 5.1. Required level of competence for setting and adjusting

The functions and accessories for positioning and relief sitting should only be set by the prescriber of the device unless otherwise agreed, as this requires knowledge of good sitting positions. For example, these features and accessories include armrest width adjustment.

Daily functions such as seat height, seat tilt, brake and, if relevant, armrest height, can be adjusted by the user himself/herself wherever appropriate and if this can be done safely.

## 5.2. Basic design

All models in the series REAL 9500 PLUS and REAL 9600 PLUS EL 24V come with a seat, backrest, armrests, base with four castors (standard: 100 mm), manual brake with brake lever (standard: 450 mm) and a fixed angle seat frame that does not permit seat tilting. Depending on the model, the device has either electric or manual height adjustment.

The standard REAL 2015 model comes with seat, back, base with four castors (75 mm), manual brake with brake lever (standard: 450 mm) and manual height adjustment.

The standard REAL 2624 model comes with seat, chest support, base with four castors (75 mm), manual brake with foot brake and manual height adjustment.

PLEASE NOTE! The basic design of the device may vary between regions and contracting entities.

### REAL 9500 PLUS

Adult model with manual height adjustment.

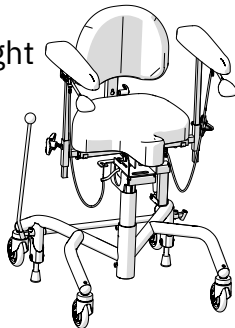

### REAL 9600 PLUS EL 24V

Adult model with electric height adjustment.

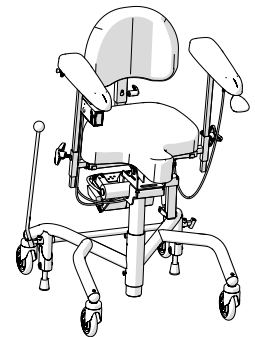

### REAL 2015

Adult model with back support and manual height adjustment.

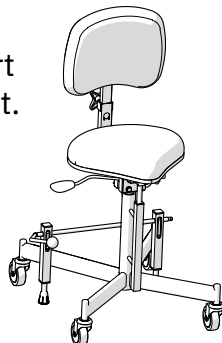

### REAL 2624

Adult model with chest support and manual height adjustment.

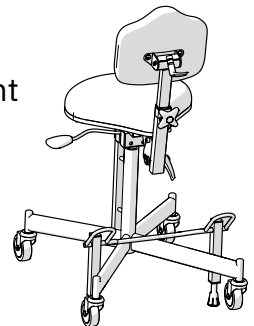

## 5.3. Electrical functions

The REAL 9600 PLUS EL 24V model featuring the RCB10+L control system can be equipped with up to three electrical functions: electric height adjustment, electric brake (optional) and electric seat tilt (optional). These can be adjusted in two ways; either using the control button located under the armrest or with the hand-held controller. The Maestro control system only supports electric height adjustment when adjusted using the control button.

The functions of electric height adjustment and electric seat tilt can be used at the same time<sup>1</sup> and will then act as an aid to getting up. This is made easier by allowing the user to raise the seat and keep their feet on the floor for the whole movement up. It also provides more controlled support when the user sits down.

<sup>1</sup> Only applies to electric models supplied from 26/05/2021.

## Control button

The control button is an electric control with three positions (off, up and down), which can be used to adjust seat height, seat tilt or back recliner. With the option of several electrical functions, the device is equipped with several control buttons. If the device is equipped with an electric brake, there is a special control button with two positions (sleep mode and switch between activated and deactivated) for this.

### Seat height

The seat height control button is located under the front edge of the right armrest, see Figure 5.1.

Adjustment:

1. Press up for upward movement.
2. Press down for downward movement.

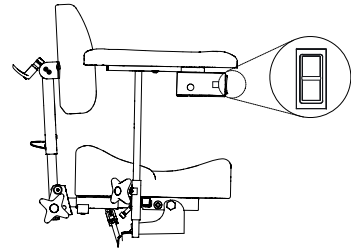

Figure 5.1. Control button for adjusting seat height.

### Brake

The brake control button is located on the outside under the right armrest, see Figure 5.2.

Activation and deactivation of brake:

1. A short press activates the brake.
2. A short press on the same button deactivates the brake.

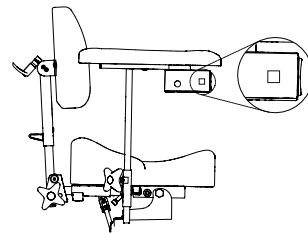

Figure 5.2. Control button for activation and deactivation of brake.

### Seat tilt

The seat tilt control button is located under the front edge of the left armrest, see Figure 5.3.

Adjustment:

1. Press up for backward seat tilt.
2. Press down for forward seat tilt.

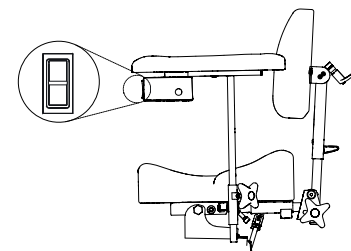

Figure 5.3. Control button for adjusting seat tilt.

## Hand-held controller

The hand-held controller (optional) is available in two versions, wired controller and wireless remote control. These are available in models with 1 function or 4 functions. The 1-function is intended to only control raising and lowering. The 4-function model can control all four functions. The hand control also has a button lock function (see Figure 5.7).

PLEASE NOTE! Only three electric functions are available for the REAL 9600 PLUS EL 24V model. The fourth, an electric backrest mechanism, is not compatible with this device.

**Seat height**

Buttons on the upper left-hand keypad (see Figure 5.4).

Adjustment:

1. Press up for upward movement.
2. Press down for downward movement.

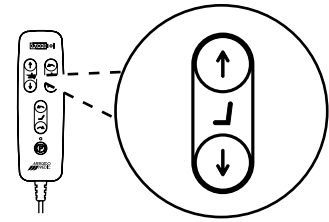

Figure 5.4. Button for adjusting seat height.

**Brake**

Button in the centre at the bottom (see Figure 5.5).

Activation and deactivation of brake:

1. A short press activates the brake.
2. A short press on the same button deactivates the brake.

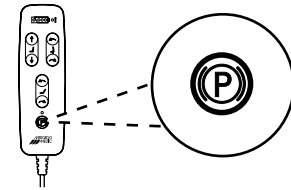

Figure 5.5. Button for activation and deactivation of brake.

**Seat tilt**

Buttons on the upper right-hand keypad (see Figure 5.6).

Adjustment:

1. Press up for forward seat tilt.
2. Press down for backward seat tilt.

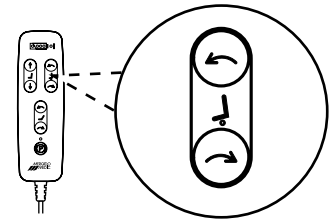

Figure 5.6. Button for adjusting seat tilt.

**Button lock**

Activating and deactivating the button lock:

1. To activate the button lock, press and hold both of the directional buttons of the relevant function for at least three seconds.
2. To deactivate the button lock, press and hold both of the directional buttons of the relevant function again for at least three seconds.

PLEASE NOTE! The button lock only locks and unlocks the function that has locked buttons. To lock multiple functions, each function must be locked separately.

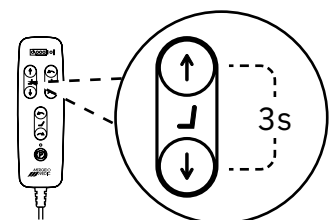

Figure 5.7. Examples of activation or deactivation of button locks for seat height.

## 5.4. Seat

The seats for the REAL 9500 PLUS and REAL 9600 PLUS EL 24V models come in two versions: Saddle and ErgoMedic. Saddle seats are available for the following models: Classic (standard: 360 x 360 mm), Medic (optional), ErgoMedic (optional), Coccyx Cut Out (optional), Round (optional), Round Comfort (optional) and Round Extra (optional). Saddle ErgoMedic is also available with memory foam padding. Compatible seats from the ErgoMedic seat system (optional) are square. These are also available in memory foam.

The REAL 2015 and REAL 2624 models have Saddle seats.

Seat upholstery is available in four materials: plush, synthetic leather (optional), patterned fabric (optional) and hygiene fabric (optional). Upholstery in hygiene fabric is used to protect the seat from moisture. Plush and hygiene fabric covers (optional) are also available for all seat designs and sizes. Hygienic fabric covers have a plush exterior and a plasticised interior. For more information about upholstery, covers and available colours, please visit our website [www.mercado.se](http://www.mercado.se). For an overview of available upholstery and covers, read the document 'Ergonomic seat systems for the REAL-chairs'.

### Saddle Classic

The Saddle Classic seat is flat with 50 mm of foam padding (see Figure 5.8). The seat comes in sizes 360 x 360 mm and 410 x 410 mm.

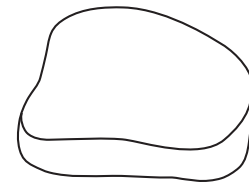

Figure 5.8. The Saddle Classic seat.

### Saddle Medic

The Saddle Medic seat is more of a positioning flat seat with a raised nose and rear edge (see Figure 5.9). The seat comes in one size: 400 x 360 mm.

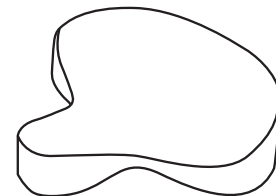

Figure 5.9. The Saddle Medic seat.

### Saddle ErgoMedic

The Saddle ErgoMedic seat is flat with a raised nose and raised outer corners on the rear edge (see Figure 5.10). The seat comes in one size: 400 x 360 mm.

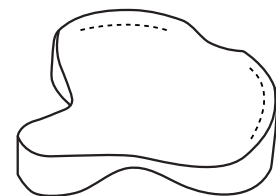

Figure 5.10. The Saddle ErgoMedic seat.

**The Saddle Coccyx Cut Out**

The Saddle Coccyx Cut Out seat is flat with a lowered rear edge to relieve the pressure on the coccyx and vertebral column (see Figure 5.11). The seat comes in one size: 400 x 360 mm.

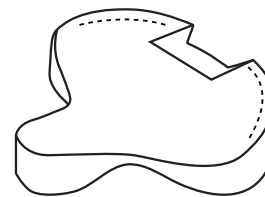

Figure 5.11. The Saddle Coccyx Cut Out seat.

**Saddle Coccyx Cut Out**

The Saddle Coccyx Cut Out seat is flat and cut out in the load zone to relieve pressure on the coccyx and vertebral column (see Figure 5.12). The seat comes in one size: 400 x 360 mm.

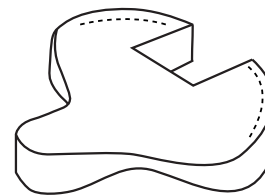

Figure 5.12. Coccyx Cut Out seat.

**Round Saddle**

The Round Saddle seat is flat with 50 mm of foam padding that is used if a wider support surface is needed (see Figure 5.13). The seat comes in sizes Ø350 mm and Ø400 mm.



Figure 5.13. The Round Saddle seat.

**Round Saddle Comfort**

The Round Saddle Comfort seat is flat with 80 mm of foam padding (see Figure 5.14). The seat has additional padding for users who need to be seated for extended periods of time and/or if a wider support surface is needed. The seat comes in one size: Ø350 mm.



Figure 5.14. The Round Saddle Comfort seat.

**Saddle Round extra**

The Saddle Round extra seat has foam shaped like a hemisphere (see Figure 5.15). The seat is primarily used for pain patients who need to find a specific load area or change the load area while seated. The seat comes in one size: Ø350 mm.

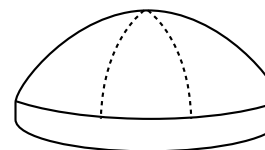

Figure 5.15. The Saddle Round extra seat.

**ErgoMedic**

The ErgoMedic seat is square with a tilted front edge (see Figure 5.16). The tilted front edge makes it possible to have a raised seat position and still reach the floor with your feet. The seat comes in sizes 400 x 320 mm and 440 x 350 mm.

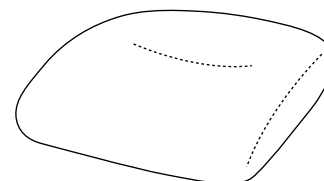

Figure 5.16. ErgoMedic seat.

## 5.5. Manual height adjustment

The REAL 9500 PLUS model comes with manual height adjustment and two seat heights: standard and low. These are also available for three different user-weight ranges: 0–55 kg, 55–90 kg and 90–150 kg. The seat height is manually adjusted with a gas spring lever placed under the armrest. Electric seat height adjustment is also available on the REAL 9600 PLUS EL 24V model, see 5.3. Electrical functions.

The REAL 2015 and REAL 2624 models have manual height adjustment in the ranges 600–800 mm and 700–900 mm. The seat height is manually adjusted with a gas spring lever placed under the seat.

**PLEASE NOTE!** Lightweight users may need help raising and lowering the gas spring controlled height adjustment.

### Gas spring lever

The lever can be placed on the right or left side (see Figure 5.17).

Adjustment:

1. Pull the lever upwards to disengage the gas spring driven lifting mechanism, then select the desired height with your feet on the floor.
2. Lock the height by releasing the lever.

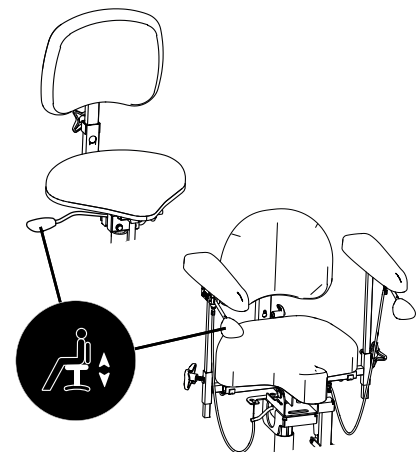

Figure 5.17. Gas spring lever for height adjustment.

## 5.6. Manual seat tilt

For the REAL 9500 PLUS and REAL 9600 PLUS EL 24V models, seat tilt is available in two ranges: 7° forward to 12° backwards; and 11° forward to 12° backwards. Manual seat tilt can be adjusted with the crank handle or gas spring lever. Electric seat tilt adjustment is also available on the REAL 9600 PLUS EL 24V model, see 5.3. Electrical functions.

The REAL 2015 model comes with a lockable seat tilt (16° forward, 20° backwards).

The REAL 2624 model comes with a lockable seat tilt (16° forward, 3° backwards).

### Gas spring lever

A lever for the gas spring is for REAL 9500 PLUS and REAL 9600 PLUS EL 24V only, and it can be placed by the left rear edge of the seat or under the left armrest (see Figure 5.18).

Adjustment:

1. Lift and hold the lever to disengage the gas spring, adjust the seat tilt by moving your upper body weight forwards and backwards until the desired position is reached.
2. Release the lever to lock the seat tilt.

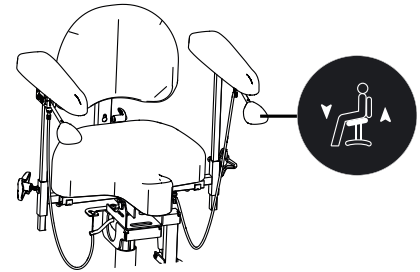

Figure 5.18. Gas spring lever for adjusting seat tilt.

### Crank handle

The crank handle is for REAL 9500 PLUS and REAL 9600 PLUS EL 24V only, and it is placed under the rear edge of the seat (see Figure 5.19).

Adjustment:

1. Turn the control to the right to move the seat tilt forwards.
2. Turn it to the left to move the seat tilt backwards.

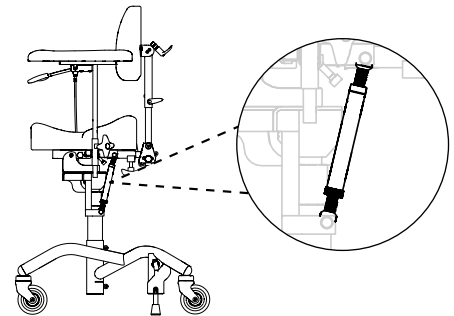

Figure 5.19. Crank handle for adjusting seat tilt.

### Lockable manual seat tilt

Lockable manual seat tilt is for REAL 2015 and REAL 2624 only, and it is placed under the seat on the left side (see Figure 5.20).

Adjustment:

1. Hold the back support/chest support in place. Loosen the handle and adjust to the desired angle.
2. Firmly tighten the handle.

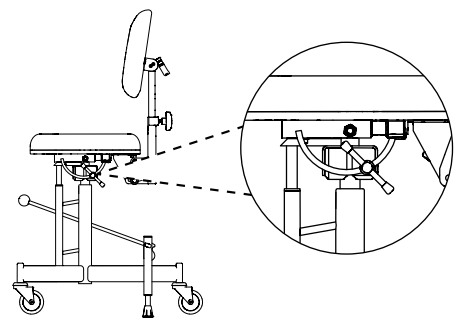

Figure 5.20. Lockable manual seat tilt.

## 5.7. Backrest

The REAL 9500 PLUS and REAL 9600 PLUS EL 24V models can be equipped with back supports in three versions: ErgoMedic, ErgoMedic Plus and Classic. ErgoMedic and ErgoMedic Plus are also available with memory foam. The models are compatible with a back support up to a height of 430 mm.

The REAL 2015 model can be equipped with a back support in three versions: ErgoMedic, ErgoMedic Plus and Classic. The model is compatible with a back support up to a height of 260 mm.

Backrest upholstery is available in four materials: plush, synthetic leather (optional), patterned fabric (optional) and hygiene fabric (optional). Plush and hygienic fabric covers (optional) are also available for all back designs and sizes. Hygienic fabric covers have a plush exterior and a plasticised interior. For more information about upholstery, covers and available colours, please visit our website [www.mercado.se](http://www.mercado.se). For an overview of available upholstery and covers, read the document 'Ergonomic seat systems for the REAL-chairs'.

### ErgoMedic

ErgoMedic is a lightly cupped back support (see Figure 5.21). The seat is available in sizes from 270 x 220 mm to 460 x 430 mm.

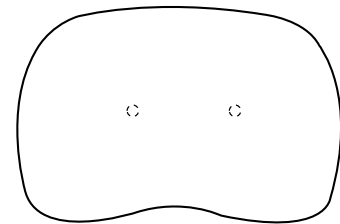

Figure 5.21. ErgoMedic backrest.

### ErgoMedic Plus

ErgoMedic Plus is a more positioning back support with built-up sides for better support (see Figure 5.22). The seat is available in sizes from 230 x 200 mm to 460 x 430 mm.

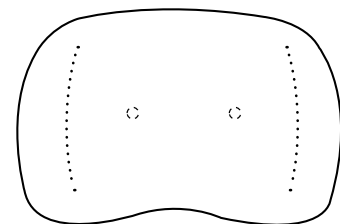

Figure 5.22. ErgoMedic Plus backrest.

### Classic

Classic is a slightly curved back support with flat padding to provide rear pelvic support (see Figure 5.23). The back support comes in one size: 330 x 160 mm.

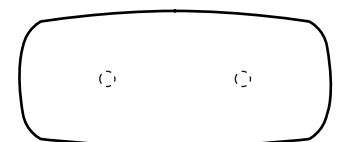

Figure 5.23. Classic back support.

## 5.8. Backrest mechanism

The Medic version of the REAL 9500 PLUS and REAL 9600 PLUS EL 24V models is equipped with a backrest mechanism. It comes in both low and high models and is adjustable in terms of height, depth and angle.

The standard version of the REAL 2015 model has a backrest mechanism. It comes in a locked model and has adjustable height, depth and angle.

PLEASE NOTE! The illustrated back mechanisms are in the low model.

### Standard

The standard model has adjustable height (A), back support angle (B) and back-rest mechanism angle (C) (see Figure 5.24). The back recliner can be adjusted in the range of 15° forward to 30° backwards.

Height setting:

1. Loosen the knob and select the desired height for the back.
2. Tighten the knob.

Setting the angle of the backrest:

1. Loosen the handle and adjust to the desired angle.
2. Tighten the handle.

Setting the angle of the back recliner:

1. Loosen the knob and adjust to the desired angle.
2. Tighten the knob securely.

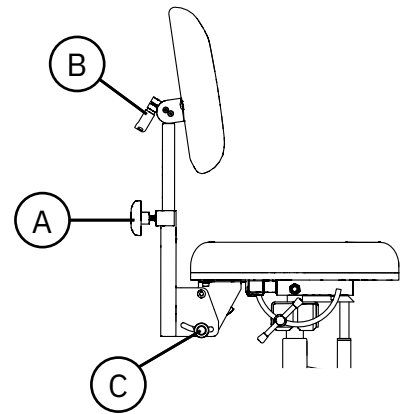

Figure 5.24. Standard backrest mechanism.

**Medic**

Medic has adjustable height (A), back support angle (B), back-rest mechanism angle (C) and depth (E) (see Figure 5.25). The back recliner can be adjusted in the range of 15° forward to 45° backwards.

To set the height and angle of the backrest and back recliner, see Standard back mechanism.

Depth setting:

1. Loosen the knob and adjust to the desired depth.
2. Tighten the knob securely.

PLEASE NOTE! Make sure that the Medic backrest mechanism is adjusted in the bracket so the spring button clip locks and the backrest mechanism cannot be pulled out.

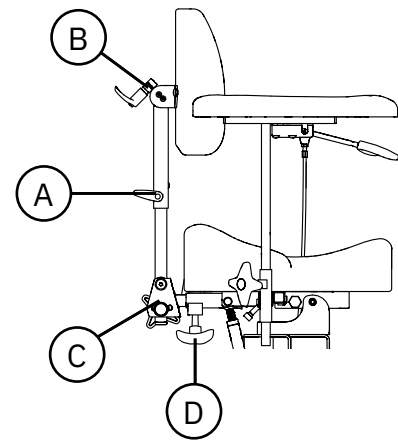

Figure 5.25. Medic backrest mechanism.

**5.9. Chest support**

The REAL 2624 model can be equipped with a chest support in three versions: ErgoMedic, ErgoMedic Plus and Classic.

**Chest plate, double nose**

A double nose chest plate has a nose at the top and at the bottom to provide a wider pressure relief area to reduce pressure on the chest (see Figure 5.26). The chest support comes in one size: 270 x 270 mm.

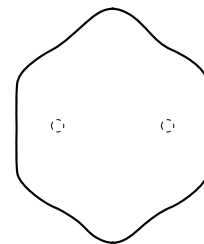

Figure 5.26. Chest plate, double nose.

**Medic**

The Medic chest plate is shaped to support the chest and minimise pressure on lungs and soft body parts (see Figure 5.27). The chest support comes in one size: 270 x 230 mm.

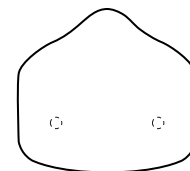

Figure 5.27. Medic chest plate.

**Classic**

Classic chest plate is a slightly curved chest support with level padding to support the chest (see Figure 5.28). The chest support comes in one size: 330 x 160 mm.

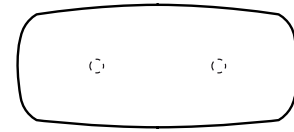

Figure 5.28. Classic chest plate.

## 5.10. Chest support mechanism

The REAL 2624 model is equipped with a chest support mechanism. The chest support mechanism has adjustable height, depth and angle.

**Chest support mechanism chest support chair**

The chest support mechanism has adjustable height (A), angle of chest support (B) and angle of chest support mechanism (C) (see Figure 5.29). The angle of the chest support mechanism is adjustable from 15° backwards to 30° forward.

Height setting:

1. Loosen the knob and select the desired height for the back.
2. Tighten the knob.

Setting the angle of the chest support:

1. Loosen the handle and adjust to the desired angle.
2. Tighten the handle.

Setting the depth of the chest support mechanism:

1. Loosen the handle and adjust to the desired angle.
2. Firmly tighten the handle.

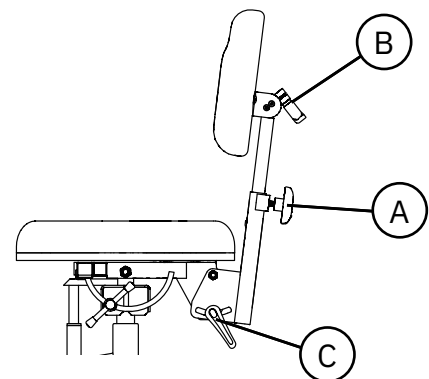

Figure 5.29. Chest support mechanism for REAL 2624.

### 5.11. Armrest panel

The REAL 9500 PLUS and REAL 9600 PLUS EL 24V models can be equipped with armrest panels in four versions: ErgoMedic, Mobil (optional), ErgoMedic Plus (optional) and Extra Soft (optional).

Upholstery for armrest panels is available in five materials, synthetic leather, plush (optional), patterned fabric (optional), hygiene fabric (optional) and genuine leather (optional). Real leather is particularly recommended for allergy sufferers. Further details about upholstery, covers and available colours are available on our website [www.mercado.se](http://www.mercado.se). For an overview of available upholstery and covers, read the document 'Ergonomic seat systems for the REAL-chairs'.

#### ErgoMedic

The ErgoMedic armrest panel is curved at the back to keep the elbow stable. The front of the armrest panel is shaped to provide a good grip for standing up and transfer (see Figure 5.30). The armrest panel is available in lengths from 250 mm to 400 mm.

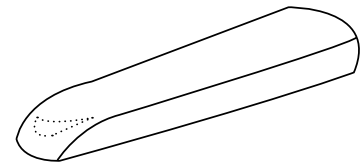

Figure 5.30. ErgoMedic armrest panel.

#### Mobile

The Mobile armrest panel has slightly thicker foam and is slightly wider than the ErgoMedic armrest panel. The front is also wider to provide more stable support when the user sits down or stands up (see Figure 5.31). The armrest panel is available in lengths from 250 mm to 400 mm.

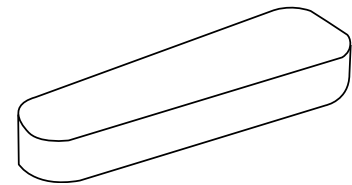

Figure 5.31. Mobile armrest panel.

#### ErgoMedic Plus

The ErgoMedic Plus armrest panel is shaped so that the arms are supported from the sides, which means that the upper body is more relieved. The front of the armrest panel is ergonomically shaped to relieve pressure on the wrist and carpal bone in a resting position, while providing the user with good support when sitting down and standing up (see Figure 5.32) at the same time. The armrest panel is available in lengths from 300 mm to 420 mm.

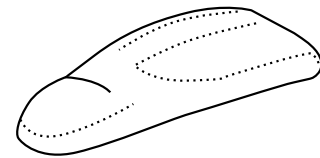

Figure 5.32. ErgoMedic Plus armrest panel.

**Extra Soft**

The Extra Soft armrest panel is a slightly wider armrest panel with a very soft and flexible foam. The armrest panel is designed for pain-sensitive users, but also works for users who sit for long periods of time, see Figure 5.33. The armrest panel is available in lengths from 250 mm to 350 mm.

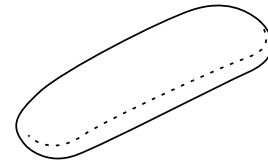

Figure 5.33. Extra Soft armrest panel.

**5.12. Armrest mechanism**

The REAL 9500 PLUS and REAL 9600 PLUS EL 24V models are equipped with Armrest Mechanism 9500. The armrests move with the seat when it is tilted.

**Armrest Mechanism 9500**

Armrest Mechanism 9500 has adjustable height (A) and width (B) (see Figure 5.34).

Height setting:

1. Loosen the knob and adjust to the desired height.
2. Tighten the knob.

Depth setting:

1. Loosen the knob and adjust to the desired width.
2. Tighten the knob.

PLEASE NOTE! Width adjustment of the armrests should be adjusted by the prescriber, as it may adversely affect the seating ergonomics if this setting is not correct. This particularly applies if the device has side supports fitted.

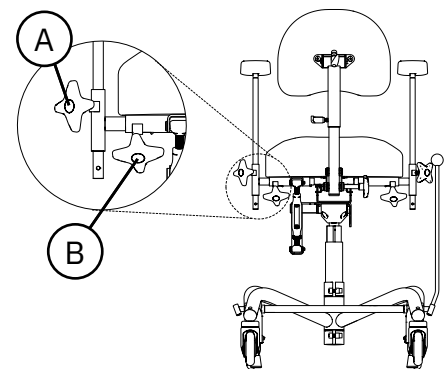

Figure 5.34. Armrest Mechanism 9500.

### 5.13. Base

The REAL 9500 PLUS and REAL 9600 PLUS EL 24V models are equipped with Base 9000 PLUS 48. This is forward braked<sup>2</sup>. The base can also be equipped with a folding foot ring (optional) in a 1/4 or 1/8 version. A 1/8 foot ring is available in both a right and left model.

The REAL 2015 model is equipped with Base 2015. This is available in two heights: 500–700 mm and 600–800 mm. The base is braked using a handbrake.

The REAL 2624 model is equipped with Base 2624. This is available in two heights: 500–700 mm and 600–800 mm. The base is braked using a foot brake at the front.

#### 9000 PLUS 48 base

The base has two brake legs and brakes forwards (see Figure 5.35).

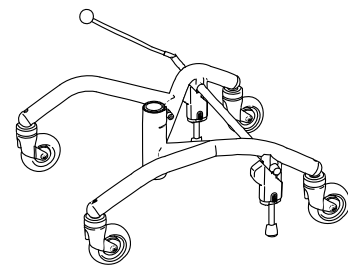

Figure 5.35. 9000 PLUS 48 base.

#### Base 2015

The base has two brake legs and it brakes forwards (see Figure 5.36).

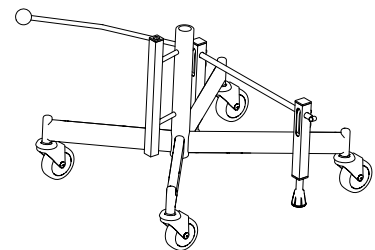

Figure 5.36. Base 2015.

#### Base 2624

The base has two brake legs and it brakes forwards (see Figure 5.37).

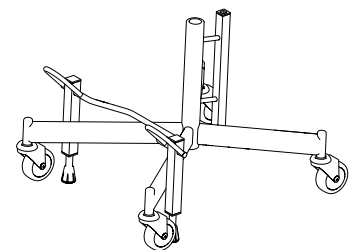

Figure 5.37. Base 2624.

<sup>2</sup> The forward and backward brakes respectively describe the position of the brake lever in the brake position. The forward brake is normally used by the user themselves. The backward brake is normally used by an assistant.

**Folding foot ring 1/4**

The folding foot ring 1/4 is mounted on the front of the base and folds up into one piece (see Figure 5.38).

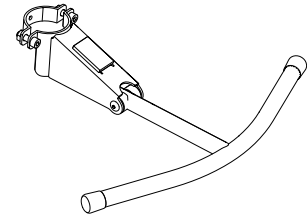

Figure 5.38. Foot ring 1/4.

**Folding foot ring 1/8**

The folding foot ring 1/8 is mounted on the front of the base and folds up into one piece (see Figure 5.39).

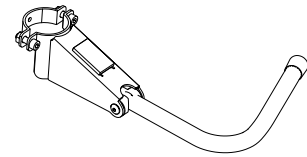

Figure 5.39. Foot ring 1/8 left model.

**5.14. Manual brake**

The REAL 9500 PLUS, REAL 9600 PLUS EL 24V and REAL 2015 models can be fitted with a manual brake in a brake lever version. The brake lever is available in two models, brake lever with knob and brake lever with loop. The brake lever with knob is available in three lengths: 250 mm (optional), 350 mm (optional) and 450 mm (standard). The brake lever with loop (optional) is available in length 530 mm. This is used to reduce the range of motion needed for the arm when braking. The brake lever bracket on the REAL 9500 PLUS och REAL 9600 PLUS EL 24V models has adjustable width. An electric brake is also available on the REAL 9600 PLUS EL 24V model, see 5.3. Electrical functions.

The manual brake for the REAL 2624 model comes in a foot brake version.

**Brake lever**

The brake lever can be placed on the right (A) or left (B) side of the base (see Figure 5.40).

Activation and deactivation:

1. Pull the brake lever to the locking position to brake.
2. Pull the brake lever in the opposite direction to disengage.

Setting the brake lever bracket:

Brake lever brackets are located on the outside of the base at the rear wheels on the right and left sides. To be able to brake even when the width of the armrest is adjusted outwards, the brake lever brackets can also be adjusted outwards (see Figure 5.41).

1. Loosen the screw on the brake lever bracket with a 6 mm Allen key. Gently pull out the bracket.
2. Attach the screw to the next hole and tighten the screw tightly with the Allen key.

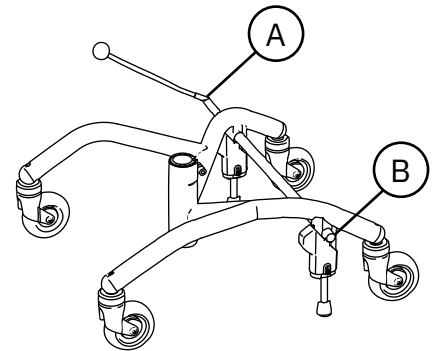

Figure 5.40. Brake lever.

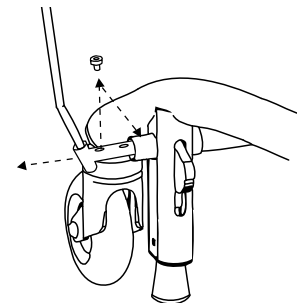

Figure 5.41. Setting the brake lever bracket.

**Foot brake**

The foot brake is placed on the brake axle at the front edge of the base (see Figure 5.42).

Activation and deactivation:

1. Push down to the locking position to brake.
2. Press up to disengage the brake.

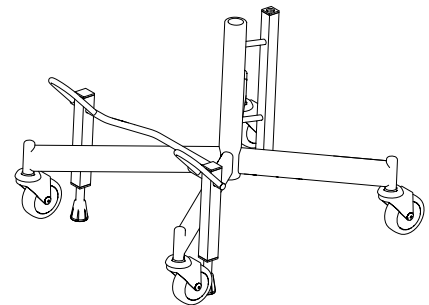

Figure 5.42. Foot brake.

### 5.15. Individual adaptation

The device must not be equipped with any accessories or components other than those approved by Mercado Medic. To maintain the CE marking, no individual modifications or changes may be carried out without Mercado Medic's approval. Modifications may be made only by personnel who have completed Mercado Medic's training for servicing and reconditioning.

Mercado Medic's devices are modular and can be customised with various accessories. The components available, as well as how to use them and what they are used for, can be found in the document 'Accessories' on [www.mercado.se/mercado-dokument](http://www.mercado.se/mercado-dokument). All accessories must be mounted and fixed so that they maintain their setting and that there is no possibility for small parts to come loose. All cables must be secured with cable ties to the device's structure to minimise the risk of strangulation.

In addition to its own range, Mercado Medic has combination agreements with several companies. A list of the current companies and components can be found under the Combination Agreements section of [www.mercado.se/mercado-dokument](http://www.mercado.se/mercado-dokument). These items may be assembled while maintaining the CE marking.

If an item that is not on the list of applicable combination agreements is fitted, the responsible organisation must carry out a risk analysis and take over device responsibility from Mercado Medic regarding the specific device. If a third-party item is frequently used on the device, you can

contact Mercado Medic with a request for a combination agreement between the supplier of the item in question and Mercado Medic. The item to be evaluated is sent to Mercado Medic, which evaluates whether combination agreements are up to date. After that, a risk analysis is carried out on the combination as desired. When a risk analysis is carried out, the customer receives a written statement and a new combination agreement is drawn up. The combination agreement is presented on the website [www.mercado.se/mercado-dokument](http://www.mercado.se/mercado-dokument).

If the following guidelines are met when individually adapting authorised personnel of an organisation other than Mercado Medic, then Mercado Medic retains device responsibility for the device.

- Padded details such as seats, back supports and armrests are adaptable, but the user must make sure not to exceed the existing outer permitted adjustment of the device.
- The user's centre of gravity must be maintained over the lifting mechanism.
- Padded parts must be able to withstand the applicable flammability requirements and other environmental requirements. If a third-party seat cushion is used, the device must be fitted with a seat mat in anti-slip material of an equivalent size in order to ensure the safety of the device.
- Surfaces that are loaded with significant vertical forces must not fall outside the area (base) that is formed by the centre points of the castors.

Devices that have undergone changes outside of the above guidelines must be verified by Mercado Medic in order for Mercado Medic to continue to retain device liability.

For devices specially adapted by healthcare services, outside Mercado Medic's directive, device liability passes to the healthcare services until the device has been restored to original condition or removed from the market. Mercado Medic will then re-assume device liability in accordance with the CE marking Regulation on Medical Devices (EU) 2017/745, MDR.

For questions regarding customisation, please contact the device Manager at Mercado Medic using the contact details of the head office under Section 1.1. Contact details.

## 6. Important safety information

Our website [www.mercado.se](http://www.mercado.se) has information about any safety notices to the market or recalls of devices and accessories.

### 6.1. Standards met and classification

Mercado Medic's standing supports and chest support chairs are CE marked in accordance with the Regulation on Medical Devices (EU) 2017/745, MDR, and the Medical Devices Agency's Code of Statutes for Medical Devices LVFS 2003:11. The devices are medical devices as defined in Article 2 of the MDR. The devices are classified as Class 1 non-invasive medical devices in accordance with Regulation 1. The active property of the device variants with electrical functions is not considered to affect the classification.

The REAL 9500 PLUS and REAL 9600 PLUS EL 24V models are tested and approved according to applicable parts of the following standards:

- EN 12182:2012
- IEC 60601-1:2005 + A1:2012
- EN 60601-1-2:2015
- EN 60601-1-11:2015 + A1:2020
- EN 1335-1:2000
- EN 1335-2:2009
- EN 1335-3:2009

The following standards have also been used in the development of the devices:

- EN 1041:2008 + A1:2013
- EN ISO 14971:2020

All textiles on the devices have been tested and approved according to the following fire protection standards:

- EN 1021-1:2014 (ignition source: lit cigarette)
- EN 1021-2:2014 (ignition source: gas flame equivalent to a burning match)

Only the underside of the seat and armrests do not have fire protection as they are wooden. All other surfaces are made of metal or clad in fire protection-rated textiles. Armrests, seats, backrests, etc. have been developed and designed to be free from toxic substances and allergens.

Models with electrical functions are classified according to IEC 60601-1:2005 as a medical device with applied part (Applied Part as defined in standard) of type B associated protection class II with internal power source.

Models with electrical functions meet protection class IP21. The first digit (2) covers contact protection for fingers, etc., preventing access to hazardous parts with fingers or similar. The second digit (1) means vertical drip protection, and so the device can therefore withstand light showers from above.

Details of EMC are available on our website at [www.mercado.se](http://www.mercado.se).

## 6.2. Warnings



Warning! As a user, you should contact your prescriber, technical aids centre or distributor if the device shows reduced or altered performance. A device showing a loss of or change in performance must immediately be taken out of use in order to avoid an accident. The device must not be used again until an authorised technician has examined the device.



Warning! To maintain safety, the device should only be used by the person and purpose for which it is intended. The device is set up for a single user. Changing settings may affect the user's seating position, which may result in damage or injury.



Warning! You are not permitted to modify the device yourself. If you would like individual customisation, contact your prescriber or distributor. If the device is modified, the CE marking no longer applies and Mercado Medic may no longer have full device liability. Modifications may affect the safety of the device and lead to accidents.



Warning! The device may be equipped with long cables or wires that cannot be secured in order for the device to function properly. Cables and wires can pose strangulation risks to small children, for example. Do not leave the device unattended with small children nearby.



Warning! Electric models may be affected by interference from mobile phones or other RF communication equipment.



Warning! The device is equipped with small parts such as screws that can come loose. Small parts that have come loose can pose choking hazards for children and pets.



Warning! Metal surfaces may become very hot if they are exposed to direct sunlight. Skin contact with hot surfaces can lead to burns. Avoid exposing metal surfaces to direct sunlight.



Warning! Always ensure that the device's brake is applied when sitting down and getting up. If the device is not braked, it risks rolling away when you get up or sit down, which can lead to fall injuries.



Warning! Repairs and other technical measures may only be carried out by personnel authorised by Mercado Medic. If this is not followed, the CE marking no longer applies and Mercado Medic may no longer have full device liability.



Warning! The device must not be loaded with loads higher than the maximum user weight. At higher loads, there is a risk that the life of the device will be shortened and components may break. If the device has been subjected to higher loads than intended, authorised personnel should carry out an overall assessment, see 6.3. Expected service life, to ensure that it remains safe to use the device.



Warning! Electric models have a lifting mechanism that can lift the user so high that it can pose a risk. If the user cannot get out of the device from its highest position, then the seat height should never be higher than the position at which the patient's feet touch the ground. The only exception to this is cases where the user can summon help via a home-help alarm or telephone.



Warning! Only batteries and chargers from Mercado Medic that have been tested and approved for use with the product may be used with models with electrical functions. If using other chargers or batteries, the CE marking is not applicable and Mercado Medic AB's device liability will cease to be valid for any cases regarding the battery, charging or other electronics.



Warning! The device must not be equipped with any accessories or components other than those approved by Mercado Medic. To maintain the CE marking, no individual modifications or changes may be carried out without Mercado Medic's approval. If unapproved components are intended to be used, see section 5.15. Individual adaptation.



Warning! Do not plug any electrical accessory, other than those customised by Mercado Medic, into the control system's contacts. Non-adapted components are at risk of breaking and in turn injuring the user. If unapproved components are intended to be used, see section 5.15. Individual adaptation.



Warning! Installation, connection or dismantling is not risk-free. If components are handled incorrectly, for example, crushing damage may occur. This type of work may therefore only be carried out by a Mercado Medic authorised technician.



Warning! All parts of the device must be installed and fixed so that there is no risk of small parts coming loose. All cables must be secured with cable ties to the device's structure to minimise the risk of strangulation.

### 6.3. Expected service life

The expected service life of the device is ten years when used in accordance with these instructions for use. The expected service life of the device is calculated from the date of manufacture of the device. The date of manufacture of the device can be found on one of the silver labels on the device's base and is in the format YYYY-MM (year and month), see Figure 6.1. The label also includes serial numbers and an identifier for the device model (UDI-DI).

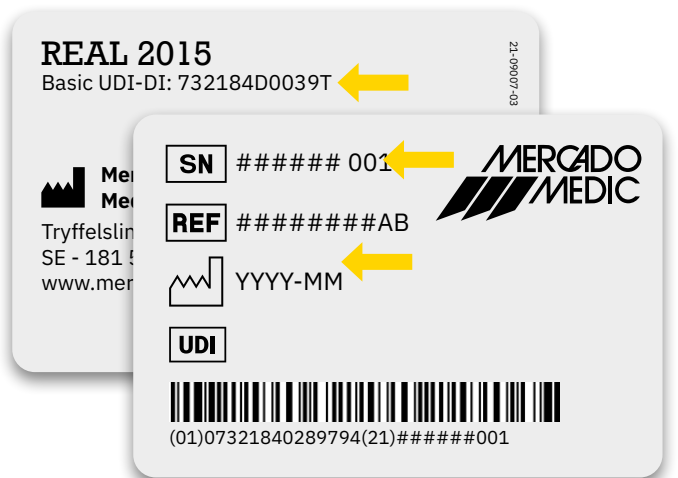

Figure 6.1. Serial number, UDI-DI and date of manufacture on the label.

PLEASE NOTE! If the serial number label and the date of manufacture are damaged or destroyed, please contact your prescriber or distributor in the first place for assistance in identifying the device, see 1.1. Contact details. Once the order number or serial number is identified, contact Mercado Medic for a replacement label.

The expected service life of accessories supplied with a Mercado Medic device is 10 years unless otherwise stated in the accompanying documentation.

The expected service life of the device battery is 5 years when the device is charged in accordance with these instructions for use, see 2.3. Charging.

In markets outside Sweden and Norway where a distributor has sold the device directly to the user (where applicable), and therefore there is no responsible prescriber, periodic maintenance must be carried out at least every other year throughout and after the device's entire expected service life. Maintenance should be carried out according to these instructions for use, see page 8. Servicing and reconditioning, in addition to the overall assessment below.

After the expected service life, Mercado Medic cannot guarantee the suitability and safety of the device, as Mercado Medic has no control over how the device has been used and its wear and tear. After the expected service life, Mercado Medic AB cannot guarantee the provision of spare parts.

### Overall assessment

After the expected service life, it is important to make an overall assessment of the device before continuing to use it. The overall assessment of the device shall be carried out by authorised personnel of the healthcare organisation if the device has been prescribed and should at least take into account:

- how the device has been used,
- what condition the device and its components are in,
- whether the device has been reconditioned and serviced,
- when reconditioning and servicing have been carried out,
- what has been remedied on the above occasions,
- and the reason for the above remedial measures.

After the expected service life, periodic maintenance at intervals of a maximum of 2 years shall be carried out according to these instructions for use, see 8. Servicing and reconditioning, in addition to the overall assessment below.

### 6.4. Reporting of adverse events and incidents

As a manufacturer of medical devices in the EU, Mercado Medic is obliged to have a system to monitor how our devices work in practical use.

Before our devices are CE-marked and placed on the market, we have taken into account the risks that may be present with them and taken measures to reduce the risks as far as possible. Nevertheless, accidents and incidents can occur when the devices are used. If this happens, it is important that this is reported to both Mercado Medic and the national relevant authority. Use contact details in these instructions for use for reporting, see 1.1. Contact details. Feel free to use email to enable faster handling.

## 7. Technical information

This section describes the dimensions and performance of the device, as well as symbols that appear on the device.



Warning! Repairs and other technical measures may only be carried out by personnel authorised by Mercado Medic. If this is not followed, the CE marking no longer applies and Mercado Medic may no longer have full device liability.

### User weight

Models	MAX
REAL 9500 PLUS	150 kg
REAL 9600 PLUS EL 24V	150 kg
REAL 2015, REAL 2624	130 kg



Warning! The device must not be loaded with loads higher than the maximum user weight. At higher loads, there is a risk that the life of the device will be shortened and components may break. If the device has been subjected to higher loads than intended, authorised personnel should carry out an overall assessment, see 6.3 Expected service life, to ensure that it remains safe to use the device.

**Device characteristics for all models**

	REAL 9500 PLUS REAL 9600 PLUS EL 24V	REAL 2015	REAL 2624
Width <sup>1</sup>	480 mm	425 mm	425 mm
Length	550 mm	495 mm	495 mm
Total height <sup>2</sup>	816–1186 mm	600–1030 mm	890–1090 mm <sup>3</sup>
Seat height <sup>4</sup>	450–820 mm	500–800 mm	500–800 mm
Seat width	350–440 mm	350–410 mm	350–410 mm
Seat depth	320–410 mm	350–410 mm	350–410 mm
Seat tilt <sup>5</sup>	-7°/+12°, -11°/+12°	-16°/+20°	-16°/+3°
Backrest height	160–430 mm	160–260 mm	160–270 mm
Backrest width	330–460 mm	330–400 mm	270–400 mm
Back support angle <sup>5</sup>	-15°/+40°	-15°/+30°	-15°/+30°
Castors	Ø100 mm	Ø75 mm	Ø75 mm
Weight	21–25 kg	14–15 kg	14–15 kg
Maximum slope of surface in braked position <sup>6</sup>	5°	5°	5°

**Device characteristics for all electric models**

Battery	805320 Battery pack 2.6Ah 24V for control system
Battery type	Sealed valve-controlled lead acid battery
Voltage, battery pack	24V (2 x series coupled 12V batteries)
Charger	805289 Battery charger 9000 30V for work chairs 24V 1.5G

On a full charge with a high electrical lifting mechanism, you can raise the chair fully up/down a maximum of 180 times with a load of 80 kg, or up to 135 times with a load of 150 kg.

The electrical functions, except raising and lowering, may be used for max. 10% of the time (max. 2 mins/20 mins). The electronics measure activity and shut down the electrical functions if this limit is exceeded. When the total usage time in the last 20 minutes is below 2 minutes, the features are automatically activated again.

1 Depending on the seat width and the adjustment of the armrests, the device may become wider.

2 Total height with ErgoMedic back support 330 x 260 mm.

3 Total height with ErgoMedic back support 270 x 230 mm.

4 These seat heights are achieved with different lifting mechanisms.

5 Negative angle (-) refers to forward tilt and positive angle (+) refers to backward tilt.

6 Applicable in all directions.

## 7.1. Symbols

The following symbols are used on the device controls, markings or in these instructions for use. For an overview of the positioning of symbols, see Figure 7.1-7.5.

### No. Manual controls

1		Seat height up/down
2		Seat tilt forwards/backwards

### No. Electric controls and control box

3		Battery level indication
4		Warning light
5		Seat height up/down
6		Seat tilt forwards/backwards
7		backrest mechanism forward/backward (not compatible with this device)
8		Brake activation/deactivation
9		Charging socket
10		Input for control
11		Connection for electric lifting mechanism
12		Seat tilt connection

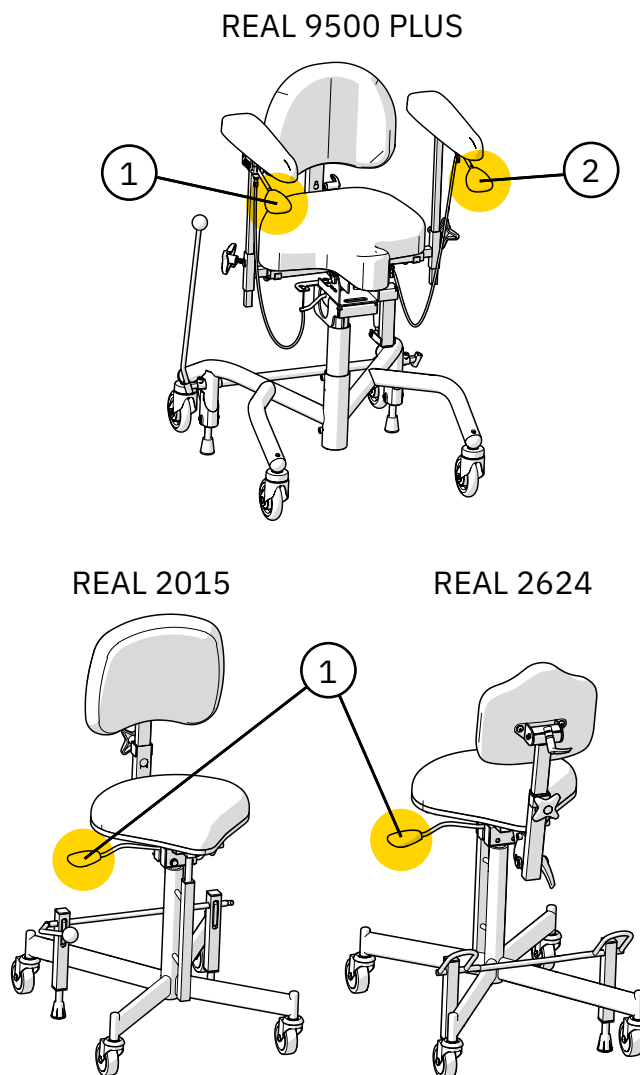















Figure 7.1. Overview of symbols on controls on manual models.

**No. Electric controls and control box**

13		Connection for backrest mechanism (not compatible with this device)
14		Brake connection
15		Read the instructions for use before use

**No. Labelling and instructions for use**

16		Warning
17		Warning, crushing risk
18		Not to be ironed
19		Do not use dry cleaning fluid stronger than perchlorine
20		Do not use chlorine bleach
21		Do not tumble dry
22		Machine wash 60°C
23		Protect from moisture
24		Handle with care
25		This side up
26		Permitted temperature

REAL 9600 PLUS EL 24V

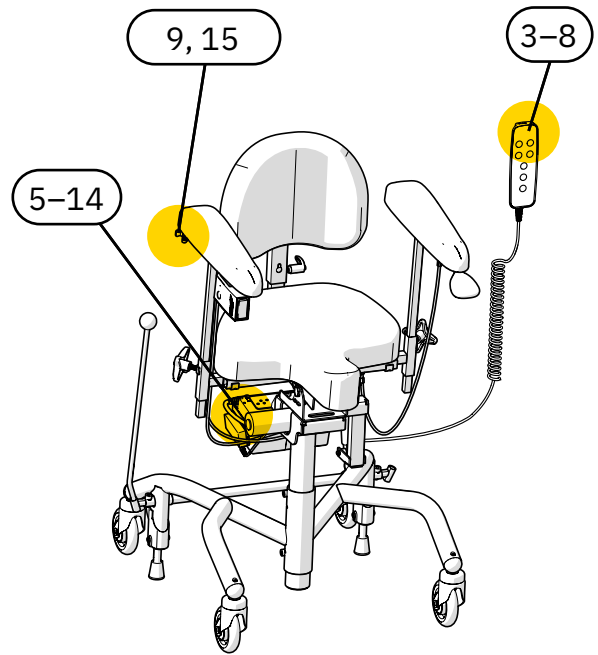

Figure 7.2. Overview of symbols on controls on electric model.



Figure 7.3. Overview of symbols on laundry care. Symbols 18–22.

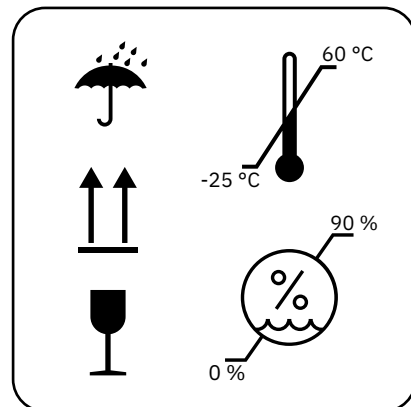















Figure 7.4. Overview of symbols on packaging. Symbols 23–27.

**No. Labelling and instructions for use**

27		Permitted relative humidity
28		Permitted altitude
29		For indoor use only
30		Maximum user weight
31		Date of manufacture
32		Manufacturer
33		Medical device
34		Serial number
35		CE mark showing the device's conformity with the European regulatory framework
36		Device classified as Type B applied part according to IEC 60601-1:2005
37		Electrical components must be disposed of at a special collection point
38		The device is part of a recycling system
39		Component weight exceeds 10 kg
40	<b>INTERMITTENS 2/20 MIN DUTY CYCLE</b>	Operating cycle

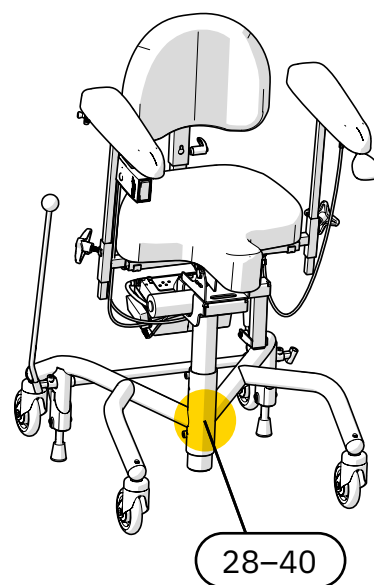

Figure 7.5. Overview of symbols on marking.

## 8. Servicing & reconditioning

This section describes the inspection and troubleshooting of the device, information about battery replacement and instructions for reconditioning the device. The troubleshooting guide is aimed at all users of the device, and the section is otherwise aimed at those who handle these parts of the device lifecycle professionally.

PLEASE NOTE! The user must not sit in the device while it is being reconditioned or serviced or during maintenance.

### Inspection during service

A thorough visual inspection must be performed of the device's main components in order to guarantee the patient's safety. The main components of the device include base, brake, lifting mechanism, seat frame, back recliner and armrest mechanism. The inspection must include welds, lockable functions and settings.

When checking the base, always inspect the weld between the base's front and rear legs. Any indication of cracks in the material or paint in this area should be regarded as reason to replace the base, or the device. Ensure good lighting and preferably use a magnifying glass, as small cracks can be difficult to detect on black lacquered bases.

In case of reduced braking action, check both the stability of the base and the condition of the brake rubber. If the device is not resting on all four wheels in the unbraked position, the device must be withdrawn from service immediately. Check the balance of the base in several locations and in several directions to exclude any influence from the floor.



Warning! Repairs and other technical measures may only be carried out by personnel authorised by Mercado Medic. If this is not followed, the CE marking no longer applies and Mercado Medic may no longer have full device liability.



Warning! As a user, you should contact your prescriber, technical aids centre or distributor if the device shows reduced or altered performance. A device showing a loss of or change in performance must immediately be taken out of use in order to avoid an accident. The device must not be used again until an authorised technician has examined the device.

## 8.1. Troubleshooting guide

If none of the following actions address the problem that has occurred, service may be required. Please contact your dealer or get in touch with Mercado Medic, see 1.1. Contact details.

### Troubleshooting for electrical functions

Symptom	Cause	Action
The control box emits an audible signal.	The device has a low or critical battery level.	Charge the device, see 2.3. Charging.
The warning light is flashing on the controller.	The work cycle, that is, the maximum time an electrical function can be used before it needs to rest, is approaching its limit. See 7. Technical information for details.	Allow the device to recover; otherwise the device will shut down the current electrical function until the device has recovered.
The electrical functions do not work. The warning light flashes when a button is pressed, if the controller is in use.	The work cycle has been exceeded, see 7. Technical information. If the limit is exceeded, all electrical functions are switched off, except for electrical height adjustment. The features cannot be used again until the system has recovered.	The device will start working again once the system has recovered. This takes up to 20 minutes.
The warning light is flashing on the hand-held controller.	The button lock has been activated.	To enable or disable the button lock for a function, press and hold both of the directional buttons of the relevant function for at least three seconds. Each function has a separate button lock.
The warning light is flashing on the hand-held controller.	An internal error has occurred.	The system will be reset automatically after 10 seconds. If the error has been resolved, then all channels will be unlocked and the warning light will be switched off.
The electrical functions do not work. No hand-held controller is used, or the controller does not display a signal on the battery level indicator lights or warning.	The battery needs to be charged or activated. If the device has been unused for 7 days or more, the battery will be automatically disconnected to maximise service life.	Charge or activate the battery by connecting the charger. It is recommended to always charge fully when doing this. For activation only, it is enough that the charger is connected for about 5 seconds.

Symptom	Cause	Action
The electrical functions do not work. The indicator shows a low battery level if the controller is in use.	The internal batteries of the device are discharged or defective.	Charge the device, see 2.3. Charging. If charging does not fix the problem, a replacement battery is needed, see 8.2. Battery replacement.
Electrical functions do not work if a button on the wireless remote control is pressed.	The batteries in the wireless remote control are empty or defective.	Replace the batteries in the wireless remote control, see 8.2. Battery replacement.
Electrical functions do not work if a button on the wireless remote control is pressed.	The remote control and IR receiver are not properly paired.	Pair the remote control and receiver. See assembly instructions for Remote control IR 24V.
The electrical functions do not work.	Defective actuator.	If the above measures have not resolved the problem, this may be because the actuator is defective and needs to be replaced.
The electrical functions do not work.	Thermal fuse has been triggered.	Maestro control system. The thermal fuses are automatically reset after a few seconds provided that no critical errors have occurred. Once reset, the electrical function will run in the opposite direction to that which it was last run in.

### Troubleshooting mechanical components

Symptom	Cause	Action
The seat slips in the direction of rotation.	Gap in the lifting mechanism.	Replace the lifting mechanism.
Noise in the electric lifting mechanism.	Worn bearings.	Replace the electric lifting mechanism.
Noise in the castors.	Worn bearings.	Replace the castors.
The device does not move smoothly.	Accumulation of hair and debris in castors.	Clean the castors, see 3. Caring for the device. Alternatively, replace the castors.
The device does not move smoothly.	Worn bearings or uneven wheel track.	Replace the castors.

The device does not brake satisfactorily.	Accumulation of dirt and dust under brake feet.	Clean the underside of the brake feet, see 3. Caring for the device.
The device does not brake satisfactorily.	The rubber brake feet have solidified over time.	Replace the brake feet <sup>1</sup>
The device does not brake satisfactorily.	The base is warped and needs to be replaced.	Replace the base and report this event to Mercado Medic. See 1.1. Contact details.

<sup>1</sup> The brakes must be checked on a regular basis, see 6. Important safety information.

## 8.2. Battery replacement



Warning! Repairs and other technical measures may only be carried out by personnel authorised by Mercado Medic. If this is not followed, the CE marking no longer applies and Mercado Medic may no longer have full device liability.

The internal batteries of the device can be replaced. Both batteries in the battery pack must be replaced at the same time. For instructions, see installation instructions 'Battery replacement 24V'.

To replace batteries in remote control, see installation instructions 'Remote control IR 24V 1G'.

Bear in mind the following when handling batteries:

- Never short-circuit the battery.
- Do not subject the battery to strong shocks.
- Always discard of used batteries at recycling centres.

### First aid

If the battery is defective and handling it results in direct contact with the contents of the battery, electrolytes (sulphuric acid), the following applies:

Incident	Action
Skin contact	Rinse with water. Clean with soap and water. Remove and wash affected clothes.
Inhalation of acid mist	Breathe fresh air. Seek medical attention immediately!
Contact with eyes	Wash eyes with running water for at least 15 minutes. Seek medical attention immediately!
When swallowed	Immediately drink plenty of water, do not induce vomiting. Seek medical attention immediately!

### 8.3. Reconditioning and periodic maintenance

The device does not require periodic maintenance in cases where it has a responsible prescriber in the healthcare sector. The prescriber and healthcare organisation are expected to follow up the prescription during the lifetime of the device according to the healthcare procedures. During this follow-up, it is important to question the performance of the device and any perceived changes. Where the device is sold by a distributor directly to the user and does not have the responsible prescriber, periodic maintenance at intervals of a maximum of 2 years must be carried out throughout and after the expected service life according to the following reconditioning instructions.

Reconditioning in these instructions for use does not refer to a full restoration or complete refurbishment in the sense referred to in the Medical Devices Regulation (EU) 2017/745, MDR, with a view to putting the device on the market again with a renewed expected service life. Reconditioning in these instructions for use aims instead at a more comprehensive review and service of the device, but where serial numbers are retained and expected service life remains unaffected. The purpose of this reconditioning may be, for example, to make the device suitable for prescribing to a new user.

#### Inspection during reconditioning

Reconditioning must include a thorough visual inspection of the device's main components in order to guarantee patient safety. The main components of the device include base, brake, lifting mechanism, seat frame, back recliner and U-bars for armrests. The inspection must include welds, lockable functions and settings.

When checking the base, always inspect the weld between the base's front and rear legs. Any indication of cracks in the material or paint in this area should be regarded as reason to replace the base, or the device. Ensure good lighting and preferably use a magnifying glass, as small cracks can be difficult to detect on black lacquered bases.

In case of reduced braking action, check both the stability of the base and the condition of the brake rubber. If the device is not resting on all four wheels in the unbraked position, the device must be withdrawn from service immediately. Check the balance of the base in several locations and in several directions to exclude any influence from the floor.

#### Replacement of components

On [www.mercado.se](http://www.mercado.se) there are various forms of substrate for changing components, such as exploded diagrams, assembly instructions, connection guides and digital item search. Installation instructions can also be used to disassemble the device's components. For accessories and spare parts please visit our webshop <https://shop.mercado.se/>.



Warning! Installation, connection or dismantling is not risk-free. If components are handled incorrectly, for example, crushing damage may occur. This type of work may therefore only be carried out by a Mercado Medic authorised technician.



Warning! All parts of the device must be installed and fixed so that there is no risk of small parts coming loose. All cables must be secured with cable ties to the device's structure to minimise the risk of strangulation.

### Long-term storage of batteries

In the event of longer term storage of the RCB10+L control system, the battery will be disconnected automatically after 7 days. The battery in the RCB10+L may also be forced into disconnected mode by plugging a 9 V power supply (part number 804823) into the charging outlet and waiting for at least 5 seconds before disconnecting the power supply. If the handheld controller is used, all of the indicator lights will flash when the battery is disconnected and the power supply can then be disconnected.

The battery in a Maestro control system does not need to be disconnected.

If storing for a longer period of time, the battery must be charged every four months in order to retain its functionality, see 2.3. Charging. If these charging instructions are followed, the battery will maintain sufficient capacity for 5 years.

To reconnect the battery to the RCB10+L control system, connect the battery charger to the charging outlet and wall socket. Wait at least five seconds before disconnecting the battery charger. The battery is now activated again and the system is ready for use. We recommend leaving the charger in place and fully charging the battery after the device has been stored with the battery in a disconnected state.

### Reconditioning instructions

Do not use high pressure washers when cleaning the device. For instructions on everyday cleaning, see 3. Caring for the device.

The following points should be performed during reconditioning to ensure patient safety:

ID	Area	Reconditioning instructions
<b>1 Cleaning</b>		
1.1	Mechanisms	Clean mechanical parts (not the actuator) using a clean, damp cloth with mild detergent (pH 7-12), surface disinfectant or use a steam cleaner (max. 8 bar).  PLEASE NOTE! Do not wash the device with water or other liquids and chemicals.
1.2	Electronics and cables	Remove dust with a dry cloth.
1.3	Operating controls	Wipe the control controls with a cloth lightly dampened with disinfectant. This is so as not to pass on any possible infection.
1.4	Actuator and lifting mechanism	Moving parts are lubricated and should therefore not be cleaned. For lifting mechanisms, see special instructions under sections 3 and 4.
1.5	Upholstery	We recommend dismantling and discarding all upholstery. Wash any covers according to the washing instructions.
1.6	Castors	Clear the castors of hair and dust.

<b>ID</b>	<b>Area</b>	<b>Reconditioning instructions</b>
<b>2 Electrical components</b>		
2.1	Electronics	Start by charging the device for at least 5 seconds to activate the electronics. Check the electronics and all electrical functions. Check for physical damage to the control box and any contact box.
2.2	Charger	Check that the charger is working and that the casing and cables are undamaged.
2.3	Controls	Make sure that the control buttons and controller are working and have no damage to the casing or cables.
2.4	Contacts	Check that cables and connectors are intact and properly secured. Check that there is no risk of crushing cables and connectors, and that all cables are fastened with cable ties.
2.5	Batteries	Check the batteries' voltage and that there is not too great a difference between the batteries' charge. A large difference in charging may indicate that a battery cell is defective. See installation instructions 'Battery replacement 24V'. Keep in mind that the life expectancy of the batteries is 5 years when maintained according to these instructions for use. This means that it may be time to replace them depending on when the reconditioning is complete and what remedial actions have been taken on the device in the past.
2.6	Electric seat tilt	Check that the actuator is not visibly damaged. Check the function of the actuator's moving parts. Check that all locking screws are tightened to avoid any play in the end position.
2.7	Electric brake	Check that the actuator is not visibly damaged. Check the function of the actuator's moving parts. Check that all locking screws are tightened to avoid any play in the end position. Check that the attachments are intact and securely fixed to the base.
<b>3 Electric lifting mechanism</b>		
3.1	Noise	Listen for noise in the lifting mechanism. Replace the lifting mechanism in case of noise. Load the device and check that the lifting mechanism does not slip when starting from the bottom position. Defective lifting mechanisms can be sent to Mercado Medic for repair.
3.2	Rotation lock	Make sure that the lifting mechanism does not have any play when rotating or loading from side to side. Replace the lifting mechanism in case of play. Defective lifting mechanisms can be sent to Mercado Medic for repair.
3.3	Lifting columns	Raise the lifting mechanism to the highest position. Wipe the lifting column of dust and dirt with a dry cloth. Then lubricate the lifting column using a thin layer of Teflon or silicone-based grease.

<b>ID</b>	<b>Area</b>	<b>Reconditioning instructions</b>
3.4	Attachment	Check that the seat is facing straight ahead relative to the base. Check that the lifting mechanism attachments to the seat frame are correctly assembled and tightened. Replace screws that have damaged key handles or threads.
3.5	Cabling	Inspect cables for any signs of wear, pinching or crushing.
<b>4 Gas spring-operated lifting mechanism</b>		
4.1	Rotation lock	Make sure that the lifting mechanism does not have any play when rotating or loading from side to side. Replace the lifting mechanism in case of play.
4.2	Lifting columns	Raise the lifting mechanism to the highest position. Wipe the lifting column of dust and dirt with a dry cloth. Then lubricate the lifting column using a thin layer of Teflon or silicone-based grease.
4.3	Attachment	Check that the seat is facing straight ahead relative to the base. Check that the lifting mechanism attachments to the seat frame are correctly assembled and tightened. Replace screws that have damaged key handles or threads.
4.4	Lock ring	Check that the lock ring under the bottom is securely fastened.
4.5	Gas spring lever	Check that the gas spring locks properly and that the height does not slowly change under load. If the height slowly changes under load, adjust the wire nipple. Check and replace damaged wires and sheaths.
<b>5 Base</b>		
5.1	Welds	Check all welds carefully for signs of cracks, corrosion and movement. Ensure good lighting and preferably use a magnifying glass, as small cracks can be difficult to detect on black lacquered bases. Make sure the base is stable. Fill in any varnish damage with touch-up paint to avoid corrosion.
5.2	Bolted joints	Check and tighten all screw joints. Replace screws that have damaged key handles or threads.
<b>6 Brakes</b>		
6.1	Function	Replace the brake feet. Check that the brake is working properly.
6.2	Plastic plugs	Check that guide bushings and plastic plugs are properly secured. Replace worn or damaged parts.
6.3	Pinch protection	Check that any pinch protection is securely mounted. If there is no pinch protection on the brake legs, it is recommended that this be installed before the device is put back into service.

<b>ID</b>	<b>Area</b>	<b>Reconditioning instructions</b>
<b>7 Castors</b>		
7.1	Function	Check castors and jumpers for wear or play. Wear or play may indicate defective bearings. Check that the castors rotate well and the housings rotate. Replace worn or damaged parts.
7.2	Attachment	Check that the castors' screws are intact and tightened. Replace screws that have damaged key handles or threads.
<b>8 Seat frame</b>		
8.1	Mechanics	Carefully check all welded parts for cracks and paint damage. In particular, check around the mounting of actuators for the seat tilt and at the holes for mounting leg supports, as these areas are particularly subject to load. Ensure good lighting and preferably use a magnifying glass, as small cracks can be difficult to detect on black lacquered structures. Fill in any varnish damage with touch-up paint to avoid corrosion.
8.2	Bolted joints	Check and tighten all screw joints. Replace screws that have damaged key handles or threads.
8.3	Plastic plugs	Check that guide bushings and plastic plugs are properly secured. Replace worn or damaged parts.
8.4	Controls	Make sure that all knobs and handles on the seat frame are working and that they lock correctly.
8.5	Gas spring-controlled seat tilt	If the device is equipped with gas spring controlled seat tilt, check that the gas spring locks the seat tilt properly. If the seat tilt slowly changes under load, adjust the wire nipple. Check and replace damaged wires and sheaths. Check for oil leaks in the gas spring. Replace the gas spring in case of oil leakage.
8.6	Crank-controlled seat tilt	If the chair is equipped with a crank-controlled seat tilt, check that there is no play and that all screws are tightened.
8.7	Lockable manual seat tilt	If the device is equipped with lockable manual seat tilt, check that the knob works and locks as intended.
<b>9 Back support and chest support mechanism</b>		
9.1	Mechanics	Check and replace any worn parts, carefully inspect for cracks in welds as they may have been heavily loaded for a long time. Ensure good lighting and preferably use a magnifying glass, as small cracks can be difficult to detect on black lacquered structures. Check that the moving parts work properly.
9.2	Attachment	Make sure that all screws, knobs and handles are easy to move and lock properly. Check that the spring button clips are working flawlessly.
9.3	Plastic plugs	Check that guide bushings and plastic plugs are properly secured. Replace worn or damaged parts.

<b>ID</b>	<b>Area</b>	<b>Reconditioning instructions</b>
<b>10 Armrests</b>		
10.1	U-bars	Carefully check the U-bars for cracks and paint damage. Check especially around welds and grooves for the locking, as these areas are particularly subject to load. Ensure good lighting and preferably use a magnifying glass, as small cracks can be difficult to detect on black lacquered structures. Fill in any varnish damage with touch-up paint to avoid corrosion.
10.2	Function	Check and replace any worn parts. Test that locking and function in moving parts are working properly. Check that knobs and screws are working and have no damage to threads or grip surfaces.
10.3	Plastic plugs	Check that guide bushings and plastic plugs are properly secured. Replace worn or damaged parts.
10.4	Armrest mechanics	Check all welds and that there is no damage to mechanical parts that may impair or weaken the structure. Ensure good lighting and preferably use a magnifying glass, as small cracks can be difficult to detect on black lacquered structures. Fill in any varnish damage with touch-up paint to avoid corrosion.
<b>11 Accessories</b>		
11.1	Restoration	Remove the accessories that should not be attached to the device in the basic version, see 5.2. Basic design.
11.2	Mechanics	Check all welds and that there is no damage to mechanical parts that may impair or weaken the structure. Ensure good lighting and preferably use a magnifying glass, as small cracks can be difficult to detect on black lacquered structures.
11.3	Function	Check and replace any worn parts. Check that the locking and function of moving parts works properly.
<b>12 Final inspection</b>		
12.1	Final inspection	Test all functions of the device. Check that all settings, electrical functions and brakes are working properly. Check that the castors are working properly and that all four wheels are in contact with the surface.
12.2	Battery sleep mode	If electrical models are to be stored, some batteries can be put into sleep mode with the intended 9V adapter, see 8.3. Reconditioning and periodic maintenance, Long-term storage of batteries.

## 9. Instructions for destruction

Devices permanently decommissioned must be dismantled and sorted in a correct and safe manner. At the website [www.mercado.se](http://www.mercado.se) there are installation instructions that can also be used to dismantle the device's components. The components should then be discarded in the relevant manner, see 9.1. Recycling sorting.



Warning! Installation, connection or dismantling is not risk-free. If components are handled incorrectly, for example, crushing damage may occur. This type of work may therefore only be carried out by a Mercado Medic authorised technician.

### 9.1. Recycling

Instructions for recycling of components.

#### Metal

- Armrest mechanism
- Backrest mechanism
- Chest support mechanism
- Base
- Seat frame
- Actuator
- Lifting mechanism
- Gas springs
- Other metal parts in devices sold by Mercado Medic

#### Electronics

- Cabling
- Control box (batteries to be dismantled and recycled separately)
- Contact box
- Hand-held controller
- Control buttons

#### Lead battery

- Batteries (discarded batteries should always be taken to environmental recycling centres)

#### Combustible

- Seat
- Backrest
- Chest support
- Armrests
- Other padded parts sold by Mercado Medic

This page has been deliberately left blank

