

INSTRUCTIONS FOR USE

for REAL 8000 PLUS Ophthalmology
Medical Clinic Chairs

Instructions for use and care



UK

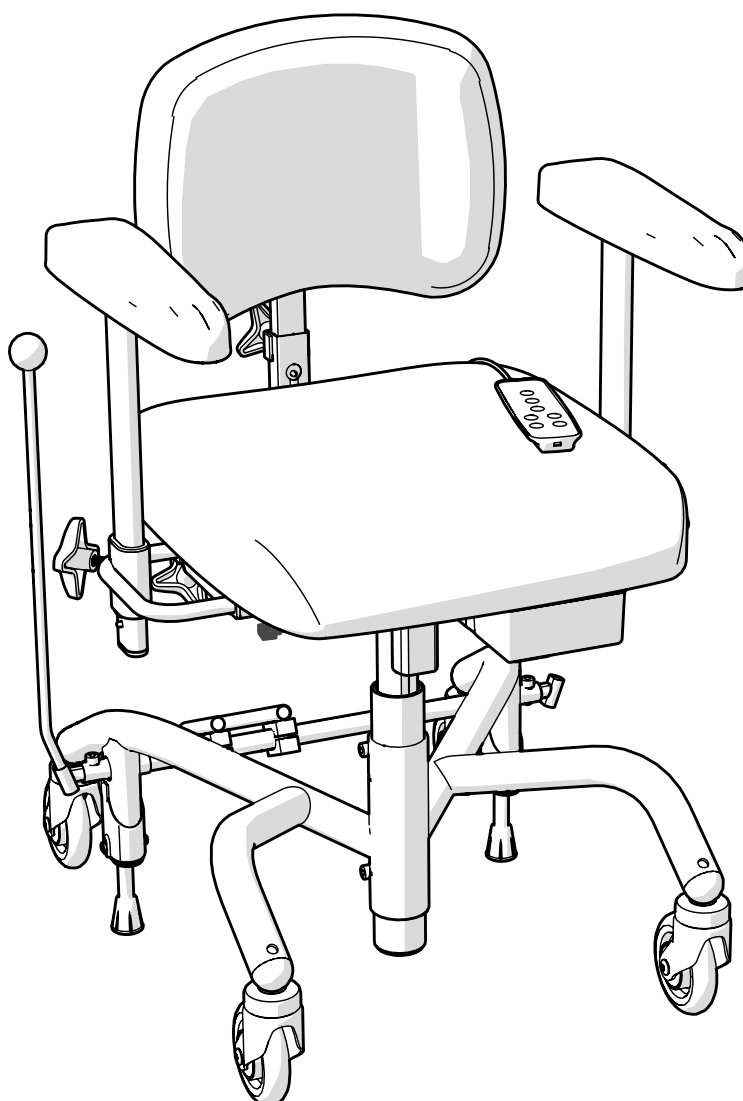

Translation of manual
Item number: 21-08997-UK
Revision: 02
Valid from: 2021-05-26
Amended: 2022-06-01



[Space for device label with
serial number]

Table of contents

User information

1. Introduction	4
1.1. Contact details	5
1.2. Warranty	5
2. Getting started	6
2.1. Before use	6
2.2. How to use the device's functions	9
2.3. Charging	9
3. Caring for the device	11
3.1. Upholstery	11
3.2. Castors and brake feet	11
3.3. Other parts	11
3.4. Transport and storage	12

Device information

4. intended use	13
4.1. Product environment	13
5. Configurations and settings	14
5.1. Required level of competence for setting and adjusting	14
5.2. Basic model	15
5.3. Electrical functions	16
5.4. Seat	17
5.5. Back support	18
5.6. Manual backrest mechanism	18
5.7. Push handles	20
5.8. Arm rest cushion	20
5.9. Armrest mechanism	21
5.10. Neck support	22

5.11. Base	23
5.12. Manual brake	24
5.13. Leg support	25
5.14. Individual customisation	27

6. Important safety information	28
6.1. Standards met and classification	28
6.2. Warnings	29
6.3. Expected service life	30
6.4. Reporting of adverse events and incidents	31

Service manual

7. Technical information	32
7.1. Symbols	34
8. Servicing & reconditioning	36
8.1. Troubleshooting guide	37
8.2. Battery replacement	39
8.3. Reconditioning and periodic maintenance	40
9. Instructions for destruction	46
9.1. Recycling	46

1. Introduction

Thank you for choosing Mercado Medic as the supplier of this device. By choosing a REAL chair, you get to learn about a 50-year history of developing medical devices with high function, safety, quality and flexibility. We manufacture all our different medical chairs under our own management in Sweden.

Mercado Medic is certified to ISO 13485, ISO 9001 and ISO 14001, and complies with applicable labour and environmental legislation.

We reserve the right to make changes to this manual and its contents.

Sufficient competence in the safe use of this device is achieved by carefully reading through these instructions for use before using the device for the first time.

PDF versions of our instructions for use with zoom options are always available in their most current version on our website www.mercado.se.



1.1. Contact details

Manufacturer

Street address: Mercado Medic AB,
Tryffelslingan 14, SE-181 57 Lidingö, Sweden

Postal address: Mercado Medic AB,
Box 1074, SE-181 22 Lidingö, Sweden
Telephone: +46 (0)8 555 143 00
Email: info@mercado.se
Website: www.mercado.se

Servicing and technical support

Telephone: +46 (0)8 555 143 08
Email: service@mercado.se

To report warranty claims, adverse events and incidents or other feedback please use the form at www.mercado.se/en/support/.

Distributor

Responsible person: Henrik Sellberg

Mercado UK Ltd
Repton House, Bretby Business Park,
Ashby Road
DE15 0YZ Burton on Trent
United kingdom

+44 (0)3330 033666
info@mercado-medic.co.uk
www.mercado-medic.co.uk

Space for additional distributor contact details:

1.2. Warranty

All components of Mercado Medic's devices are covered by warranty, under the time periods and general terms and conditions set out below, unless other specific periods and conditions are agreed in writing between Mercado Medic and the contracting customer in connection with major procurements.

As a user, you should contact your prescriber, assistive technology centre or distributor if you experience problems with the device. Distributors in turn should contact Mercado Medic using the contact details available under Section 1.1. Contact details.

Warranty periods

- Metal structures: 3 years.
- Electric lifting mechanism: 2 years.
- Other components (e.g. wheels, batteries, padded parts): 1 year.

General terms and conditions

The warranty does not cover:

- Damage or condition considered to be normal wear and tear.
- Damage caused by negligence or misuse.
- Spare parts, components or accessories not sold by Mercado Medic.
- Adjustments to the device made by unauthorised service technicians.
- Components previously fitted to devices other than the item in question.
- Bleaching or natural variations in the colours of faux leather.

2. Getting started

As the operator of the device, this section is primarily aimed at you. It describes how to prepare the device for use, how to use its functions, and how to charge it. For care instructions, see 3. Caring for the device.

If you have any questions about the device or if something unexpected has happened, please contact your distributor first. You can find up-to-date contact details in Section 1.1. Contact details. You are also welcome to contact us at Mercado Medic.

2.1. Before use

All devices come with a seat, back support, armrests, brake and electric height adjustment. When delivered from Mercado Medic, the backrest and brake lever are not yet fitted. These should always be fitted before the device is first used.

Backrest mechanism

Place the back rest support post in the back rest mechanism (B) and set the desired height level, see Figure 2.1. Tighten all levers (A). The image shows one of several back mechanisms available for Mercado Medic devices. For adjusting back supports and backrest mechanisms, see 5.6. Backrest mechanism and back support.

Brake lever

We recommend that the brake lever not be mounted if you intend to use the foot brake. If you intend to use the handbrake function, mount the brake lever as follows: Insert the brake lever into the brake lever bracket (A), see Figure 2.1. The brake lever can be placed on the right or left side.

Armrests

Loosen the armrest controls (C) and set the desired height and width levels, see Figure 2.1. Tighten all controls (C). If the product is supplied with foldable armrests, check that the knob clicks into the locking position when the armrest is lowered. If the knob does not click in position, rotate the knob until it clicks firmly.

Neck support

If the device is supplied with a neck support, insert the neck support mechanism into the backrest bracket (D) and set the desired height level, see Figure 2.1. Tighten all controls (D).

Battery

Before initial use, activate and charge the battery. This is done by connecting the battery charger to the device's charging socket and to a wall outlet (E), see Figure 2.1. The charging socket can be placed in different places on the device. The device is usually delivered with the charging socket mounted at the rear edge under the seat.

Wait until the battery is fully charged before using the device. This normally takes 2 to 5 hours. When the battery is fully charged, the LED on the charger lights up green. For other charging instructions, see 2.3. Charging.

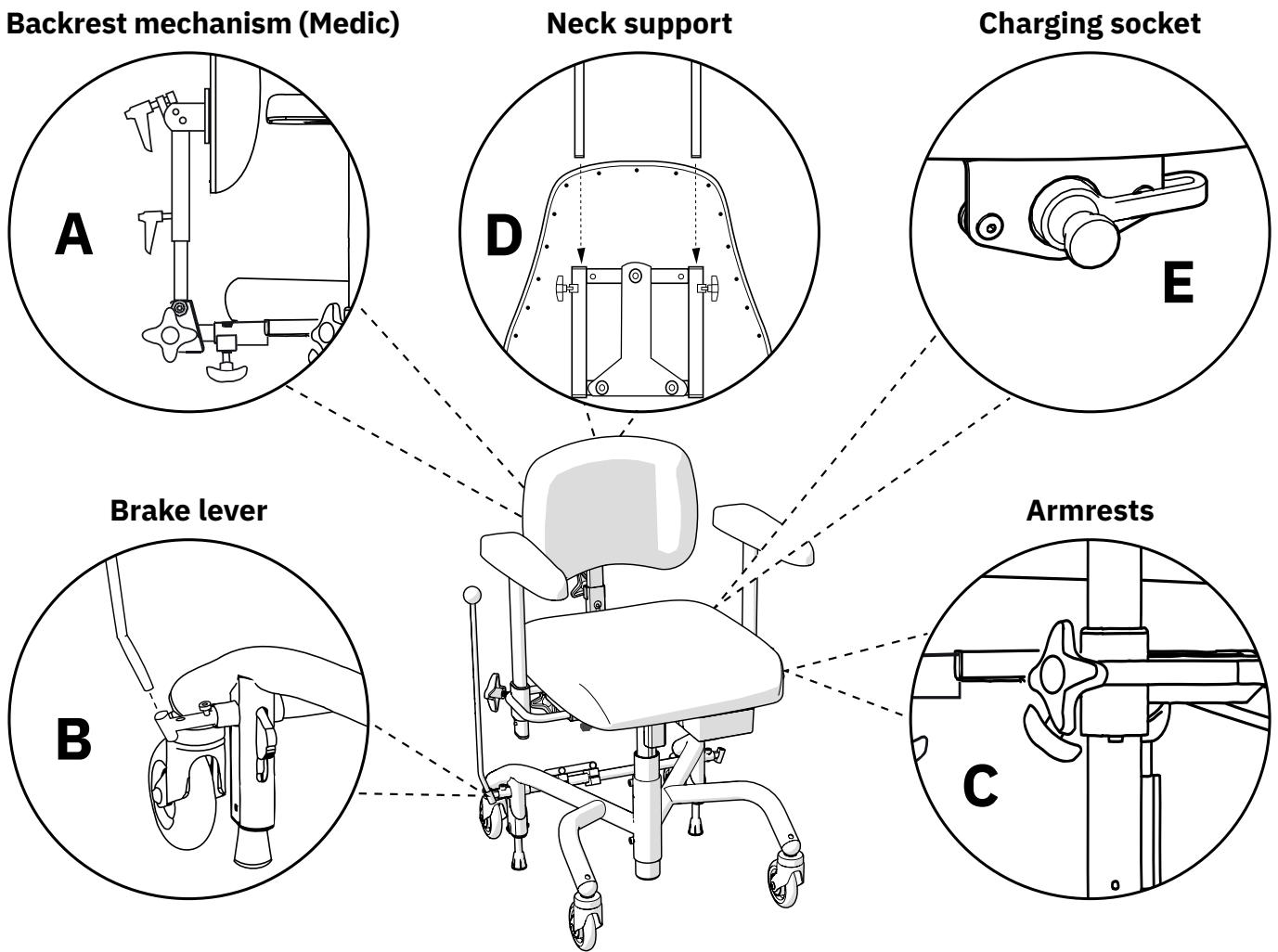

Figure 2.1. Preparations before the device is put into use.

Consider the following before and during use of the device

- Tighten all setting controls before putting the device into service.
- The device must not be used without fitting the backrest.
- The device must not be used without fitting the armrests.
- The brake on the device must always be applied when the patient gets in and out of the chair.
- The braking capacity of the device may be impaired on heavily sloping floors.
- The braking capacity of the device may be impaired on uneven floors.
- The device must be operated with care.
- If the device is equipped with leg supports, the patient's feet must always be in contact with the foot plate when electrical functions are used.
- If the device is equipped with leg supports, the leg support must not be adjusted so that it is touching the floor.
- The optional leg support is designed for you to rest your feet on, not to stand on.
- The optional foot support ring is designed to rest your feet on, not to stand on.
- Charge the device according to these instructions for use, see 2.3 Charging.

- The electrical functions cannot be used when the device is charging.
- Never set the seat to a height that makes it unsafe for the patient to get out of the device.
- The device must not be moved when the seat is in the raised position.
- Emergency stop for hand-held controller: If, for whatever reason, the system does not interrupt a movement after the corresponding control button has been released, the movement can be interrupted by pressing any of the other buttons on the hand-held controller.
- Button lock on hand-held controller: To enable or disable the button lock for a function, press and hold both of the directional buttons of the relevant function for at least three seconds. The button lock locks only the current function. To lock multiple functions, each function must be locked separately.



Warning! As a user, you should contact your distributor if device performance deteriorates or changes. A device showing a loss of or change in performance must immediately be taken out of use in order to avoid an accident. The device must not be used again until an authorised technician has examined the device.



Warning! You are not permitted to modify the device yourself. Please contact your distributor if you would prefer individual customisation. If the device is modified, the CE marking no longer applies and Mercado Medic may no longer have full device liability. Modifications may affect the safety of the device and lead to accidents.



Warning! The device may be equipped with long cables or wires that cannot be secured in order for the device to function properly. Cables and wires can pose strangulation risks to small children, for example. Do not leave the device unattended with small children nearby.



Warning! The device is equipped with small parts such as screws that can come loose. Small parts that have come loose can pose a potential choking hazard for children.



Warning! Metal surfaces may become very hot if they are exposed to direct sunlight. Skin contact with hot surfaces can lead to burns. Avoid exposing metal surfaces to direct sunlight.



Warning! Always make sure that the device's brake is applied when the patient sits down and gets up. If the device's brake is not applied, there is a risk that the device will roll away when the patient stands up or sits down, which could cause fall injuries.

2.2. How to use the device's functions

The product is equipped with electric height adjustment (A) and is controlled by a wired hand-held controller or wireless remote control, see Figure 2.2. The device is also equipped with manual foot brake and hand brake. The manual foot brake (B) is activated and deactivated via a pedal and the manual handbrake (C) is activated by pushing the brake lever forwards and deactivated by pulling the brake lever backwards, see Figure 2.2. We recommend not mounting the brake lever if you intend to use the foot brake. See 5. Configurations and settings for detailed information about all the features and controls of the device.

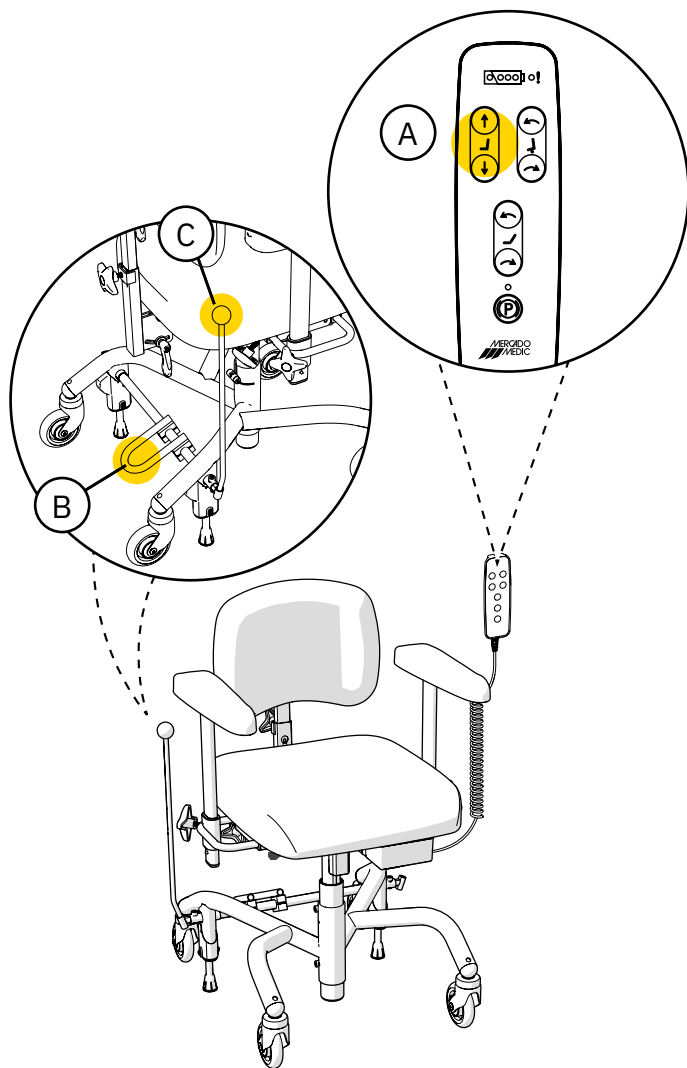

Figure 2.2. Controls on real 8000 PLUS EL 24V Easy low.

2.3. Charging

The battery should be charged once every 24 hours. Fully charging the battery on a daily basis will take 2 to 5 hours. It is important that the battery is never completely discharged, as this helps to prolong the life of the battery. Daily battery charging is especially important for configurations with an electric brake and seat tilt. The device emits a low battery level warning sound, for both low and critical. Low battery is indicated by a short signal. Critical battery level is indicated by a short signal that ends with a loud beep. The product can also indicate low or critical battery levels using a signal when the product's battery is activated after the system has been in sleep mode. This is because when starting up, the product has not yet determined its charge level. This signal stops after two minutes. The battery level can also be read on the indication lights on the hand-held controller, see Figure 2.3.



Figure 2.3. Battery level indicator on hand-held controller.

The device must be charged in a safe manner. The electrical functions cannot be used when the device is charging. For this reason, choose an easily accessible wall socket to plug the charger into. The charger cable to the wall socket is 1 metre long and must not be extended. In case of emergency, disconnect the device from the mains by unplugging the charger from the wall socket.

How to charge the device

1. Inset the plug into the charging outlet (see Figure 2.4). The charging outlet is usually placed in the rear edge under the seat.
2. Connect the charger plug into the wall socket. The LED on the charger will indicate that charging is underway.
3. The battery is fully charged when the LED on the charger changes colour from red to green. This will also be shown when the three green battery LEDs on the hand-held controller battery indicator being flashing in sync.

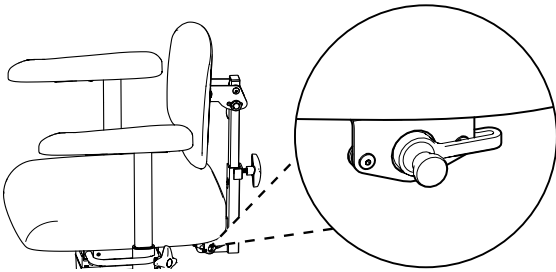

Figure 2.4. Charging socket plug connection under the seat.

If the electrical functions have not been used for 7 days, the battery switches off automatically. To reconnect the battery, connect the battery charger to the charging socket and the wall outlet and wait at least 5 seconds before unplugging the charger. It is recommended to charge the battery fully after the battery has been disconnected.

If no electrical functions are working, try charging the battery. Contact your distributor if electrical functions still do not work, see 1.1. Contact details.

3. Caring for the device

Clean the device in accordance with the instructions in this section in order to maintain functions and service life. If needs arise that cannot be resolved with the resources available, please contact your distributor for reconditioning.

PLEASE NOTE! Do not wash the device with water or other liquids and chemicals.

3.1. Upholstery

To prevent contamination, device upholstery must be cleaned after each period of use.

Synthetic leather padded parts

Use soap and water or surface disinfectant to clean synthetic leather padded parts. Start by removing any loose debris. Then use a cloth to clean the upholstery with soap and water or surface disinfectant. If the upholstery is cleaned using soap and water, finish by wiping with a clean, damp cloth.

3.2. Castors and brake feet

Regular cleaning of castors and brake feet is required to maintain the operation of the device. Wipe castors and brake feet with a damp cloth. Remove any hair from the castors using a thin crochet needle or similar implement.

3.3. Other parts

The device's lifting mechanism and other actuators, see Figure 3.1 (may be in electric seat tilt, back recliner and brake), should not be cleaned. This is because there is a risk that the grease required for these mechanisms to function as intended might be removed during cleaning.

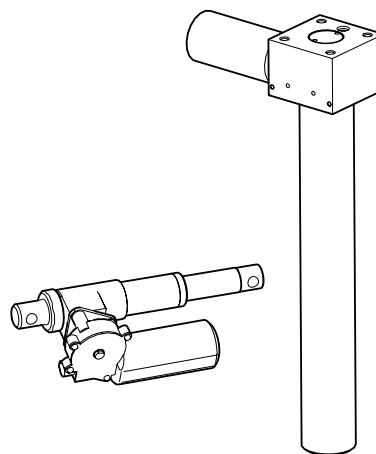

Figure 3.1. device's lifting mechanism and other actuators.

If necessary, a dry cloth can be used to remove dust from any electronic parts of the device. Clean the other non-electronic parts of the device once a week or when necessary. Use a clean, damp cloth with mild detergent (pH 7-12), surface disinfectant or use a steam cleaner (max. 8 bar).

3.4. Transport and storage

When transporting and storing the device, keep the following in mind:

- The device moves by rolling on a flat surface.
- The device should be lifted by two people. Suitable grip points are at the front, rear, right and left sides of the seat, see Figure 3.2.

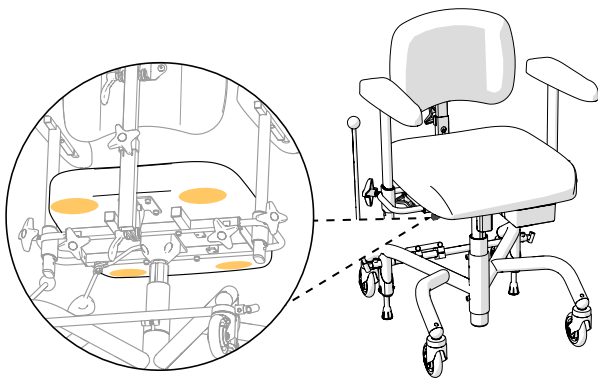
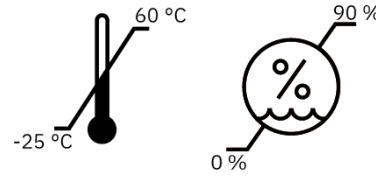

Figure 3.2. Suitable grips when lifting.

- The device is intended to be transported and stored at between -25°C to $+60^{\circ}\text{C}$ and up to 90% non-condensing relative humidity.



- The device must be transported in the intended cardboard box on a pallet. If the device is transported by car, it must be strapped in place using straps over both the base and the seat, and it should be set to the lowest possible seat height. To reduce the size of the device during transport, the backrest can be removed and the armrests lowered. Be sure to select the settings so that they can be easily reset. Tape or similar easily removable marking is recommended.
- The device must not be used as a seat when transported in a car or aircraft, for example.
- In the case of air transport, the device must be stored in the hold. Original Mercado Medic batteries are approved for air transport. For information on battery type, see 7. Technical information.

4. intended use

The REAL 8000 product range consists of modular patient seats designed to be used in combination with primary clinical examination equipment, such as X-ray machines. The device is intended to be used in conjunction with other medical equipment in environments and situations that may require customised seat positions for different patients in order to perform the examination efficiently and with satisfactory results. Applicable situations include, but are not limited to, mammography and other radiological examinations, as well as various kinds of ophthalmological examinations. REAL 8000 is designed to be used wherever a good seat position is required, such as in the following situations:

- the patient has to be able to cope with a complete examination.
- the patient needs support to remain still enough in order for the examination method to give satisfactory results:
- for example, the patient needs support to remain still enough during a biopsy.
- being able to carry out more efficient examinations in situations where there is a need to reduce the time the patient has to endure an emotional strain (such as during a mammogram).

The REAL 8000 product range is designed to be operated by a professional who ensures an appropriate adjustment in relation to both the patient and the primary examination equipment.

Contraindications

There are no known contraindications for using the REAL 8000 product range.

4.1. Product environment

- The device is intended for indoor use only and must not be used outdoors.
- The device is intended to be used at between -5°C to +40°C and 15-90% non-condensing relative humidity. If the device is stored in an environment outside these limits, the device must be acclimatised for up to 4 hours to achieve an approved temperature before use.

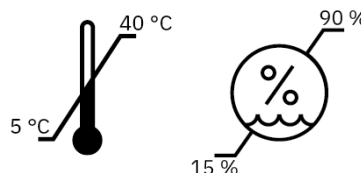

- The device must not be used at altitudes greater than 2000 m above sea level.
- The device must not be exposed to extreme cold or heat, prolonged sunlight or other radiation.
- The device must not be exposed to water, liquids or chemicals to any extent other than that specified in the care information in Section 3. Caring for the device.

5. Configurations and settings

It describes the device's models, options when configuring the device, and information about setting and adjusting the device's functions. For dimensions and performance, see 7. Technical information.

The device is available in four configurable models. The basic design of each model is described below, see 5.2. Basic design. In addition to the basic model, there are a wide variety of options for adapting the device. For available options, see the description for each function in this section. The device can also be equipped with additional accessories. For more information, please visit our website www.mercado.se or contact customer service, see 1.1. Contact details. For an overview of available accessories, we recommend reading the "REAL Eye Clinic Chairs" document. It is also possible to further customise the device both within and outside CE marking, see 5.14. individual customisation.

The product is compatible with the ErgoMedic seat system. The seat system comprises seats, back supports and armrests. The padded parts can be combined as needed for support, relief and stability when sitting. For more information about the seating systems and other upholstery, please visit our website www.mercado.se. For an overview of available upholstered details, read the document 'Seat systems'.

Data sheets and order forms are found on www.mercado.se. There are also instructions for use and device information for all Mercado Medic devices.

5.1. Required level of competence for setting and adjusting

To attain the right position for correct X-rays, the device's seat height, seat tilt, back rest and back rest mechanism should be adjusted for each patient. Only the operator may make settings and adjustments.

5.2. Basic model

The device is always supplied with a seat, back rest, armrests, base with four castors (ø 100 mm as standard), a foot brake with hand brake and an angular seat frame that does not allow for seat tilt. Four models of the device are available, Easy low, Easy high, Easy low extra and Easy high extra. The models can also be customised as desired. For more information, please contact customer service, see 1.1. Contact details.

PLEASE NOTE! The basic model of the device may vary depending on the agreement between Mercado Medic and the customer.

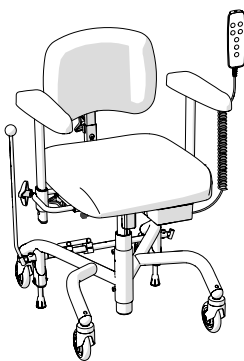
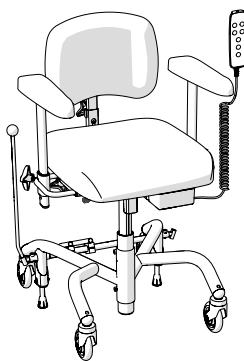
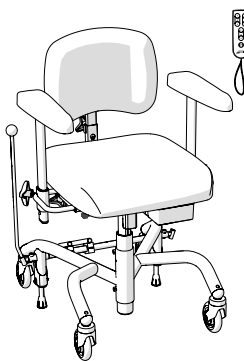
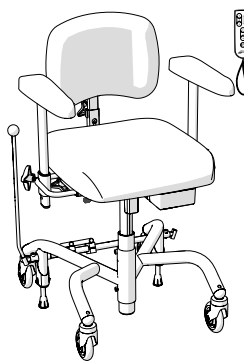
	REAL 8000 PLUS EL 24V Easy low	REAL 8000 PLUS EL 24V Easy high	REAL 8000 PLUS EL 24V Easy low extra	REAL 8000 PLUS EL 24V Easy high extra
				
Width ¹	430 mm			
Length	550 mm			
Height adjustment	Electric height adjustment with a hand-held controller		Electric height adjustment with wireless remote control	
Seat height	370–570 mm	450–730 mm	370–570 mm	450–730 mm
Seat tilt	No			
Back recliner	Manual			
Back rest mechanism interval ²	-15°/+30°			
Brake	Manual foot and hand brake			
Castors	Ø100 mm			
Seat	ErgoMedic 440 x 480 mm			
Back support	ErgoMedic 380 x 260 mm			
Armrests	PLUS armrest (350 mm as standard)			
Fabrics	Faux leather, (see www.mercado.se for available colours)			

1 Depending on the seat width and the adjustment of the armrests, the device may become wider.

2 Negative angle (-) refers to forward tilt and positive angle (+) refers to backward tilt.

5.3. Electrical functions

The device can be equipped with up to four electrical functions: electric height adjustment, optional electric brake, optional electric seat tilt and optional electric back rest mechanism. These are adjusted via a wired hand-held controller (standard on models REAL 8000 PLUS EL 24V Easy low and REAL 8000 PLUS EL 24V Easy high) or a wireless remote control (standard on models REAL 8000 PLUS EL 24V Easy low extra and REAL 8000 PLUS EL 24V Easy high extra).

Hand-held controller

The hand-held controller comes in models with 1 or 4 functions. The 1-function is intended to only control raising and lowering. The 4-function can control all four functions. The hand-held controller also has a button lock function, see Figure 5.5. The corresponding models and functionalities are also available for wired hand controls.

Seat height

Buttons on the top left-hand keypad (see Figure 5.1).

Adjustment:

1. Press up for upward movement.
2. Press down for downward movement.

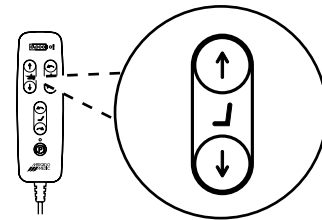

Figure 5.1. Button for adjusting seat height.

Brake

Button in the centre at the bottom (see Figure 5.2).

Activation and deactivation of brake:

1. A short press activates the brake.
2. A short press on the same button deactivates the brake.

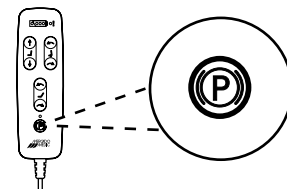

Figure 5.2. Button for activation and deactivation of brake.

Seat tilt

Buttons on the upper right-hand keypad (see Figure 5.3).

Adjustment:

1. Press up for forward seat tilt.
2. Press down for backward seat tilt.

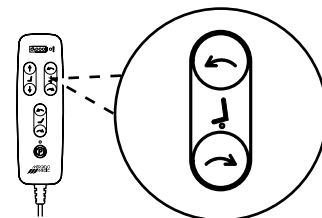

Figure 5.3. Button for adjusting seat tilt.

Back recliner

Buttons on the lower keypad in the middle, see Figure 5.4.

Adjustment:

1. Press up to move the back recliner forwards.
2. Press down to move the back recliner backwards.

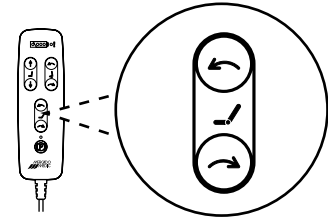

Figure 5.4. Button for adjusting back recliner.

Button lock

Activating and deactivating the button lock:

1. To activate the button lock, press and hold both of the directional buttons of the relevant function for at least three seconds.
2. To deactivate the button lock, press and hold both of the directional buttons of the relevant function again for at least three seconds.

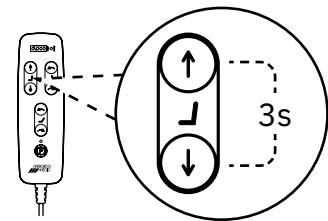

Figure 5.5. Examples of activation or deactivation of button locks for seat height.

PLEASE NOTE! The button lock only locks and unlocks the function that has locked buttons. To lock multiple functions, each function must be locked separately.

5.4. Seat

Seats are available in the ErgoMedic model.

Seat upholstery is available in two materials: faux leather and hygiene fabric (optional). Upholstery in hygiene fabric is used to protect the seat from moisture. Further details about upholstery and available colours are available on our website www.mercado.se.

ErgoMedic

ErgoMedic is a flat seat with seat indentation and additional support under the thighs (see Figure 5.6). The seat is available in sizes from 290 x 320 mm to 480 x 530 mm.

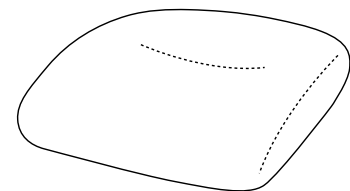

Figure 5.6. ErgoMedic seat.

5.5. Back support

Back rests are available in the ErgoMedic model.

The fabric for back rests is in faux leather. Further details about fabrics and available colours, please visit our website www.mercado.se.

ErgoMedic

ErgoMedic is a lightly cupped back rest, see Figure 5.7. The seat is available in sizes from 270 x 220 mm to 460 x 430 mm.

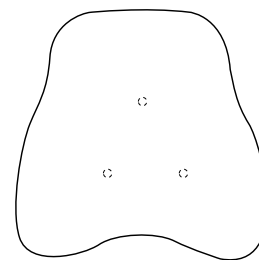

Figure 5.7. ErgoMedic backrest.

5.6. Manual backrest mechanism

There are three versions of the manual back mechanism: Standard (standard), Medic (optional) and Fixed back mechanism with push bar (optional). Standard and Medic back mechanisms are available in a low and high model. Back recliner adjustment is also available as an electrical function, see 5.3. Electrical functions.

PLEASE NOTE! The illustrated back mechanisms are in the low model.

Standard

Standard can be adjusted in height (A), angle of back rest (B) and angle of back rest mechanism (C), see Figure 5.8. The back recliner can be adjusted in the range of 15° forward to 30° backwards.

Height setting:

1. Loosen the knob and select the desired height for the back.
2. Tighten the knob.

Setting the angle of the backrest:

1. Loosen the handle and adjust to the desired angle.
2. Tighten the handle.

Setting the angle of the back recliner:

1. Loosen the knob and adjust to the desired angle.
2. Tighten the knob securely.

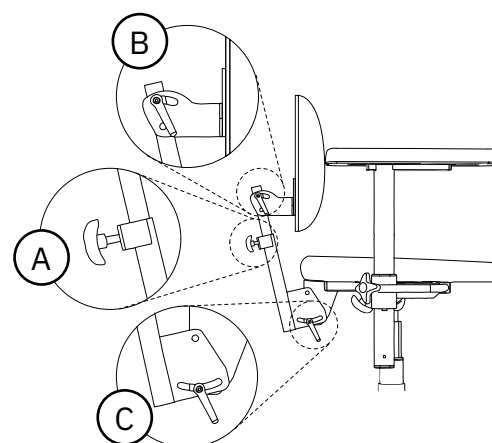

Figure 5.8. Standard backrest mechanism.

Medic

Medic can be adjusted in height (A), angle of back rest (B), angle of back rest mechanism (C) and depth (D), see Figure 5.9. The back recliner can be adjusted in the range of 15° forward to 45° backwards.

To set the height and angle of the backrest and back recliner, see Standard back mechanism.

Depth setting:

1. Loosen the knob and adjust to the desired depth.
2. Tighten the knob securely.

PLEASE NOTE! Make sure that the Medic backrest mechanism is adjusted in the bracket so the spring button clip locks and the backrest mechanism cannot be pulled out.

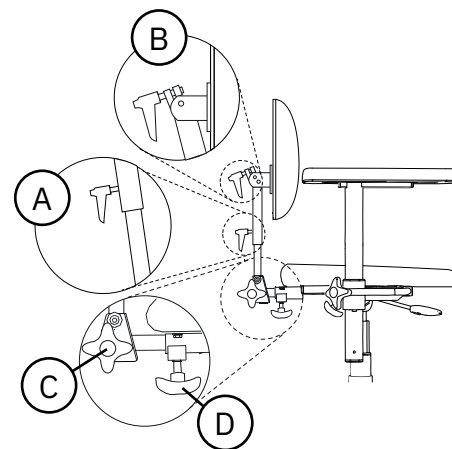

Figure 5.9. Medic backrest mechanism.

Fixed back mechanism with high back with push bar

The back rest can be adjusted at an angle using the back rest mechanism, see Figure 5.10. The back rest mechanism has a fixed angle.

Setting the angle of the backrest:

1. Loosen the handle and adjust to the desired angle.
2. Tighten the handle.

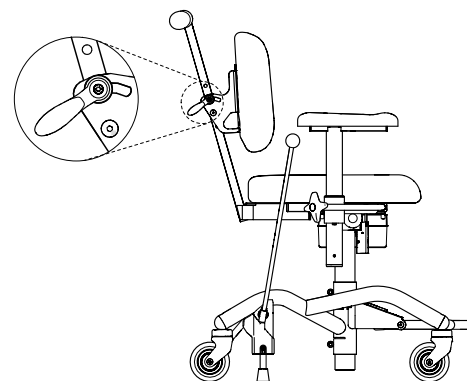

Figure 5.10. Fixed back rest mechanism with high back with push bar.

5.7. Push handles

Push handles (accessories) are available in the Clinic Push Handle version.

Clinic Push Handle

The height and angle (A) of the push handle can be adjusted, see Figure 5.11.

Adjustment of height and angle:

1. Loosen the knobs and adjust to the desired height and angle.
2. Tighten the knobs.

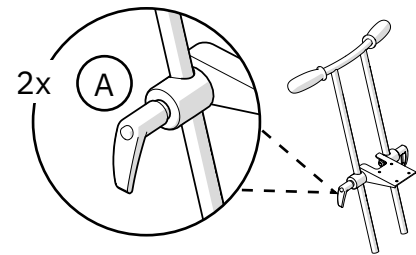

Figure 5.11. Clinic push handle.

5.8. Arm rest cushion

Three version of armrest plates are available: ErgoMedic (350 mm as standard), Mobile (optional) and optional armrest panel for armrests for sampling. For more information on armrests for sampling, we recommend you consult the documents "REAL Eye Clinic Chairs" and "Armrest sampling" installation instructions on our website www.mercado.se.

Armrest panel fabric is available in faux leather. Further details about fabrics and available colours, please visit our website www.mercado.se.

ErgoMedic

The ErgoMedic armrest panel is curved at the back to keep the elbow stable. The front of the armrest panel is shaped to provide for good grip when standing up and transferring, see Figure 5.12. The armrest panel is available in lengths from 250 mm to 350 mm.

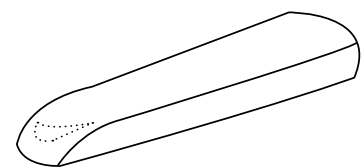

Figure 5.12. ErgoMedic armrest panel.

Mobile

The Mobile armrest panel has slightly thicker foam and is slightly wider than the ErgoMedic armrest panel. The front edge is also wider to provide more stable support when the user sits down or stands up, see Figure 5.13. The armrest panel is available in lengths from 250 mm to 350 mm.

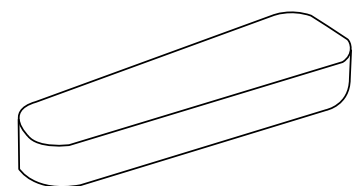

Figure 5.13. Mobile armrest panel.

5.9. Armrest mechanism

Three versions of the armrest mechanism are available in three versions: PLUS armrests, foldable armrests (optional) and armrests for sampling (optional). For more information on armrests for sampling, we recommend you consult the documents "REAL Eye Clinic Chairs" and "Armrest sampling" installation instructions on our website www.mercado.se.

PLEASE NOTE! When using the electric seat tilt, the armrests are mounted so that they follow the seat when it is angled.

PLUS armrest

The height (A) and the width (B) of the PLUS armrest are adjustable, see Figure 5.14.

Height setting:

1. Loosen the knob and adjust to the desired height.
2. Tighten the knob.

PLEASE NOTE! Tighten the knob fully on the PLUS armrest.

Depth setting:

1. Loosen the knob and adjust to the desired width.
2. Tighten the knob securely.

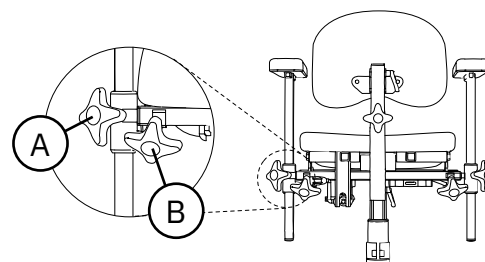

Figure 5.14. PLUS armrest.

Foldable armrests

Foldable armrests have adjustable in height (A) and width (B) and can be folded backwards (C), see Figure 5.15.

For height and width adjustment, see PLUS armrest.

Folding the armrests:

1. Pull out the knob, and if necessary turn it so that it locks in the extended position.
2. Hold the armrest and rotate the armrest backwards to fold it.
3. Rotate the armrest forwards to fold it back.
4. Make sure the knob clicks into the locked position. If the knob does not click in position, rotate the knob until it clicks firmly.

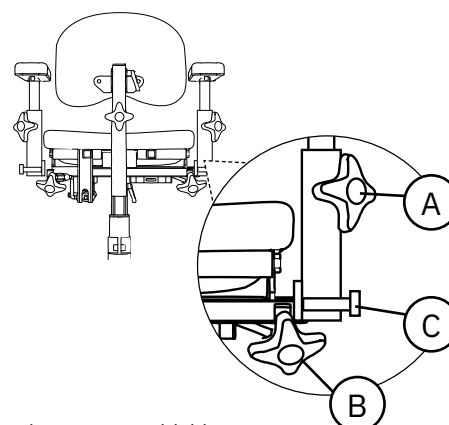

Figure 5.15. Foldable armrests.

5.10. Neck support

There are two optional head rest versions available: Flat and Cupped.

Available fabric for head rest is faux leather. Further details about fabrics and available colours, please visit our website www.mercado.se.

Neck support mechanism

The head rest is adjustable in height (A), depth (B) and angle (C), see Figure 5.16.

Height setting:

1. Loosen the wheels and adjust to the desired height.
2. Tighten the wheels.

Depth setting:

1. Loosen the knobs and adjust to the desired depth.
2. Tighten the knobs.

Adjusting the angle:

1. Loosen the handle and adjust to the desired angle.
2. Tighten the handle.

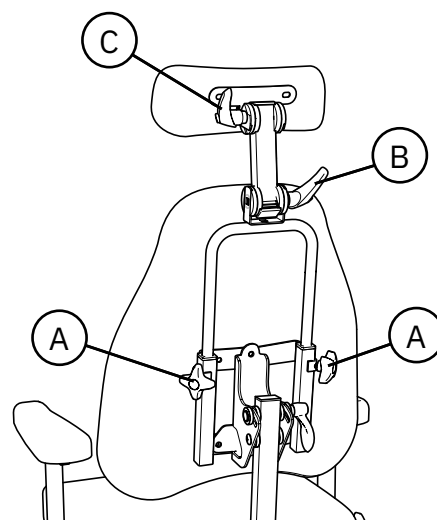

Figure 5.16. Neck support mechanism

Plan head rest cushion

Plan head rest cushion is flat in shape and available in size 290 x 160 mm, see Figure 5.17

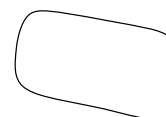

Figure 5.17. Plan head rest cushion

Plan head rest cushion Cupped

Headrest cushion Cupped has a cupped shape and is available in size 310 x 180 mm, see Figure 5.18.

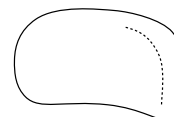

Figure 5.18. Plan head rest cushion Cupped

5.11. Base

There are two Base designs available: Base Plus Clinic 43 (standard) and Base Plus Clinic 48. Bases are available in models with reverse brake (standard) and forward brake (optional).³ The base can also be equipped with a foldable foot ring 1/4 (optional).

Bases are available in white (standard) and black (optional) colours.

Based Plus Clinic 43

The base has two brake legs and is reverse braked, see Figure 5.19.

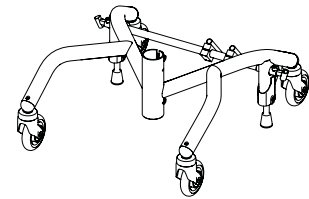

Figure 5.19. Base Plus Clinic 43.

Base Plus Clinic 48

The base has two brake legs, and it is reverse braked, see Figure 5.20.

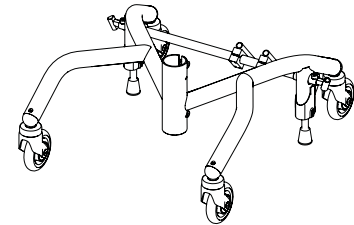

Figure 5.20. Base Plus Clinic 48.

Folding foot ring 1/4

Foldable foot ring 1/4 is located at the front edge of the base and folds up into one piece, see Figure 5.21.

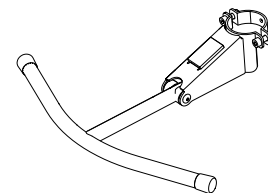

Figure 5.21. Foot ring 1/4.

³ The forward and backward brakes respectively describe the position of the brake lever in the brake position.

5.12. Manual brake

Two versions of manual braking are available: a foot brake and a brake lever (optional). The brake lever is available in two models, brake lever with knob and brake lever with loop. The brake lever with knob is available in three lengths: 250 mm (optional), 350 mm (standard) and 450 mm (optional). The brake lever with loop (optional) is available in length 530 mm. This is used to reduce the range of motion needed for the arm when braking. The brake is also available as an electrical function, see 5.3. Electrical functions.

Foot brake

If the device is equipped with a foot brake, this is located on the base's brake axle (see Figure 5.22).

Activation and deactivation:

1. Push down to the locking position to brake.
2. Press upwards on the underside of the pedal to disengage the brake.

PLEASE NOTE! The brake must be in locked mode whenever the patient is sitting down on or getting out of the chair.

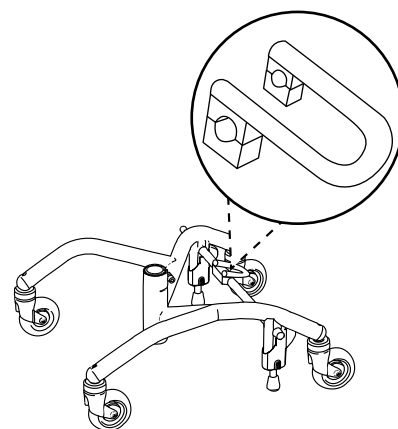

Figure 5.22. Foot brake.

Brake lever

The brake lever can be located on the right (A) or left (B) side of the base, see Figure 5.23.

Activation and deactivation:

1. Pull the brake lever to the locking position to brake.
2. Pull the brake lever in the opposite direction to disengage.

Setting the brake lever bracket:

Brake lever brackets are located on the outside of the base at the rear wheels on the right and left sides. To be able to brake even when the width of the armrest is fully adjusted outwards, the brake lever brackets can also be adjusted outwards, see Figure 5.24.

1. Loosen the screw on the brake lever bracket with a 6 mm Allen key. Gently pull out the bracket.
2. Attach the screw to the next hole and tighten the screw tightly with the Allen key.

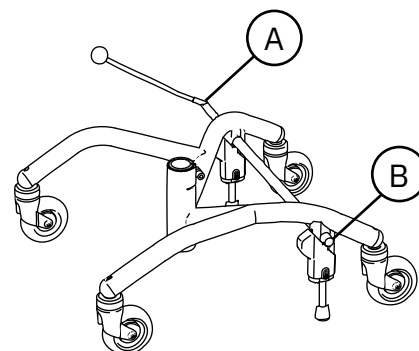

Figure 5.23. Brake lever.

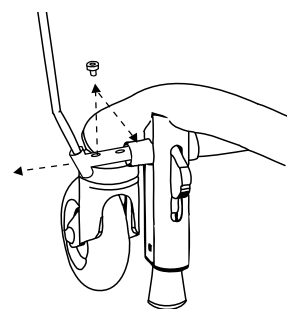

Figure 5.24. Setting the brake lever bracket.

5.13. Leg support

Manual leg rests (optional) are available in the centre-mounted version. The centre-mounted leg support has a full footplate and is adjustable in height, leg support angle and footplate angle. The angle of the leg support can be adjusted to four different positions. The device can be equipped with an optional adapter to be combined with Cross leg support from ETAC (external supplier). Cross leg supports are removable without tools, follow the seat when adjusting height and can be rotated sideways to facilitate entering and exiting. The leg support is available in three models, Standard fixed angle, Tight fixed angle where the angle of the knee becomes closer to 90° and Angular. All models are adjustable in height and angle of footplate and are available with foot plates of different widths.

Centre-mounted

The centre-mounted leg support is adjustable in height (A), angle of leg support (B) and angle of foot plate (C), see Figure 5.25.

Setting the height of the footplate:

1. Loosen the wheel and pull or push the footplate to the desired height.
2. Tighten the knob.

Setting the angle of the leg support:

1. Unscrew the screw with a 5 mm Allen key and set the desired angle.
2. Tighten the screw.

Setting the angle of the footplate:

1. Adjust the screw with 5 mm Allen key.
Screw clockwise to angle the footplate down.
Screw anti-clockwise to angle the footplate up.

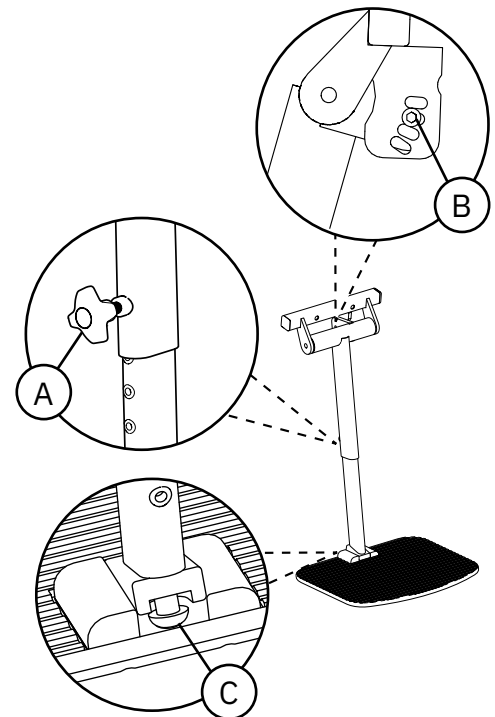

Figure 5.25. Centre-mounted leg support.

Cross leg support adapter

The Cross leg support, see Figure 5.26, is mounted on the armrest width adjustment U-bar. The adapter can be mounted in two depth positions for different deep seats and be fine-tuned steplessly to 50 mm in depth. For more information, see the installation instructions "Adapter leg support, Cross" available at the www.mercado.se.

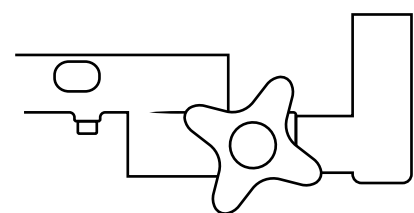

Figure 5.26. Cross leg support adapter.

Cross leg support

Cross leg supports are removable without tools and can be rotated sideways. The leg supports are adjustable in height (A), angle of leg support (B) and angle of foot plate (C), see Figure 5.27.

Rotate the leg supports to the side:

1. Lift the leg support straight up about 15 mm and rotate outwards.

Installing the leg support:

1. Insert the leg support into the adapter bracket.
2. Rotate the leg support until it is facing straight ahead and is fixed to the bracket.

Installing a leg support:

1. Lift the leg support out of the adapter bracket.

Setting the height of the footplate:

1. Loosen the wing nut on the back of the leg support tube. Remove the front screw and adjust to the desired length.
2. Insert the screw through the pipe and screw on the wing nut. Tighten the wing nut.

Setting the angle of the footplate:

1. Loosen the two screws on the outside of the footplate 1 to 2 turns with a 5 mm Allen key. Angle the footplate to the desired position.
2. Tighten the screws.

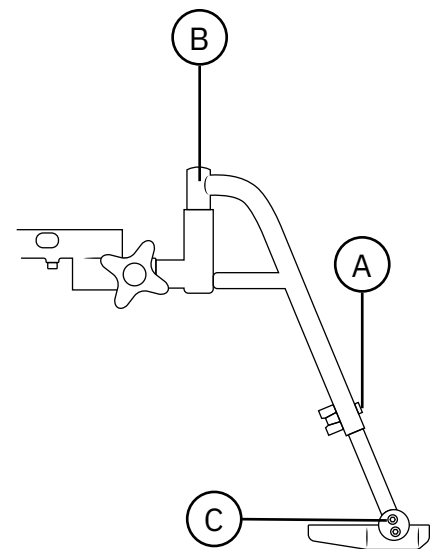

Figure 5.27. Cross leg support.

5.14. Individual customisation

The device must not be equipped with any accessories or components other than those approved by Mercado Medic. To maintain the CE marking, no individual modifications or changes may be carried out without Mercado Medic's approval. Modifications may be made only by personnel who have completed Mercado Medic's training for servicing and reconditioning.

If the following guidelines are met when individually adapting authorised personnel of an organisation other than Mercado Medic, then Mercado Medic retains device responsibility for the device.

- Padded details such as seats, back supports and armrests are adaptable, but the user must make sure not to exceed the existing outer permitted adjustment of the device.
- The patient's centre of gravity must be maintained over the lifting mechanism.
- Padded parts must be able to withstand the applicable flammability requirements and other environmental requirements. If a third-party seat cushion is used, the device must be fitted with a seat mat in anti-slip material of an equivalent size in order to ensure the safety of the device.
- Surfaces that are loaded with significant vertical forces must not fall outside the area (base) that is formed by the centre points of the castors.

devices that have undergone changes outside of the above guidelines must be verified by Mercado Medic in order for Mercado Medic to continue to retain device liability.

For devices specially adapted by healthcare services, outside Mercado Medic's directive, device liability passes to the healthcare services until the device has been restored to original condition or removed from the market. Mercado Medic will then re-assume device liability in accordance with the CE marking Regulation on Medical Devices (EU) 2017/745, MDR.

For questions regarding customisation, please contact the device Manager at Mercado Medic using the contact details of the head office under Section 1.1. Contact details.

6. Important safety information

Our website www.mercado.se has information about any safety notices to the market or recalls of devices and accessories.

6.1. Standards met and classification

Mercado Medic's clinic chairs are CE marked in accordance with the Regulation on Medical Devices (EU) 2017/745, MDR, and the Medical Devices Agency's Code of Statutes for Medical Devices LVFS 2003:11. The devices are medical devices as defined in Article 2 of the MDR. The devices are classified as Class 1 non-invasive medical devices in accordance with Regulation 1. The active property of the device variants with electrical functions is not considered to affect the classification.

The devices are tested and approved according to the following standards:

- EN 12182:2012
- IEC 60601-1:2005 + A1:2012
- EN 60601-1-2:2015
- EN 60601-1-11:2015 + A1:2020
- EN 1335-1:2000
- EN 1335-2:2009
- EN 1335-3:2009

The following standards have also been used in the development of the devices:

- EN 1041:2008 + A1:2013
- EN ISO 14971:2020

All textiles on the devices have been tested and approved according to the following fire protection standards:

- EN 1021-1:2014 (ignition source: lit cigarette)
- EN 1021-2:2014 (ignition source: gas flame equivalent to a burning match)

Only the underside of the seat and armrests do not have fire protection as they are wooden. All other surfaces are made of metal or clad in fire protection-rated textiles. Armrests, seats, backrests, etc. have been developed and designed to be free from toxic substances and allergens.

Models with electrical functions are classified according to IEC 60601-1:2005 as a medical device with applied part (Applied Part as defined in standard) of type B associated protection class II with internal power source.

Models with electrical functions meet protection class IP21. The first digit (2) covers contact protection for fingers, etc., preventing access to hazardous parts with fingers or similar. The second digit (1) means vertical drip protection, and so the device can therefore withstand light showers from above.

6.2. Warnings



Warning! As a user, you should contact your distributor if device performance deteriorates or changes. A device showing a loss of or change in performance must immediately be taken out of use in order to avoid an accident. The device must not be used again until an authorised technician has examined the device.



Warning! You are not permitted to modify the device yourself. Please contact your distributor if you would prefer individual customisation. If the device is modified, the CE marking no longer applies and Mercado Medic may no longer have full device liability. Modifications may affect the safety of the device and lead to accidents.



Warning! The device may be equipped with long cables or wires that cannot be secured in order for the device to function properly. Cables and wires can pose strangulation risks to small children, for example. Do not leave the device unattended with small children nearby.



Warning! The device is equipped with small parts such as screws that can come loose. Small parts that have come loose can pose a potential choking hazard for children.



Warning! Metal surfaces may become very hot if they are exposed to direct sunlight. Skin contact with hot surfaces can lead to burns. Avoid exposing metal surfaces to direct sunlight.



Warning! Always make sure that the device's brake is applied when the patient sits down and gets up. If the device's brake is not applied, there is a risk that the device will roll away, which could lead to fall injuries.



Warning! Repairs and other technical measures may only be carried out by personnel authorised by Mercado Medic. If this is not followed, the CE marking no longer applies and Mercado Medic may no longer have full device liability.



Warning! The device must not be loaded with loads higher than the maximum user weight. At higher loads, there is a risk that the life of the device will be shortened and components may break. If the device has been subjected to higher loads than intended, authorised personnel should carry out an overall assessment, see 6.3. Expected service life, to ensure that it remains safe to use the device.



Warning! Electric models have a lifting mechanism that can lift the user so high that it could pose a risk. If the patient is unable to get out of the device from its highest position, the seat height must never be higher than the position at which the patient's feet touch the ground.



Warning! Only batteries and chargers from Mercado Medic that have been tested and approved for use with the product may be used with models with electrical functions. If using other chargers or batteries, the CE marking is not applicable and Mercado Medic AB's device liability will cease to be valid for any cases regarding the battery, charging or other electronics.



Warning! The device must not be equipped with any accessories or components other than those approved by Mercado Medic. To maintain the CE marking, no individual modifications or changes may be carried out without Mercado Medic's approval. See section 5.14 if a non-approved component is going to be used. individual customisation.



Warning! Do not plug any electrical accessory, other than those customised by Mercado Medic, into the control system's contacts. Non-adapted components are at risk of breaking and in turn injuring the user. See section 5.14 if a non-approved component is going to be used. individual customisation.



Warning! Installation, connection or dismantling is not risk-free. If components are handled incorrectly, for example, crushing damage may occur. This type of work may therefore only be carried out by a Mercado Medic authorised technician.



Warning! All parts of the device must be installed and fixed so that there is no risk of small parts coming loose. All cables must be secured with cable ties to the device's structure to minimise the risk of strangulation.

6.3. Expected service life

The expected service life of the device is ten years when used in accordance with these instructions for use. The expected service life of the device is calculated from the date of manufacture of the device. The date of manufacture of the device can be found on one of the silver labels on the device's base and is in the format YYYY-MM (year and month), see Figure 6.1. The label also includes serial numbers and an identifier for the device model (UDI-DI).

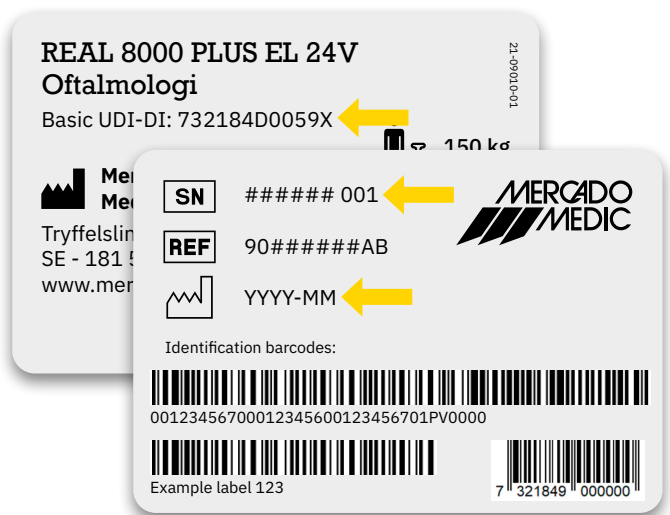

Figure 6.1. Serial number, UDI-DI and date of manufacture on the label.

PLEASE NOTE! If the label indicating the serial number and date of manufacture is damaged or destroyed, contact your distributor first for assistance in identifying the device, see 1.1. Contact details. Once the order number or serial number is identified, contact Mercado Medic for a replacement label.

The expected service life of accessories supplied with a Mercado Medic device is 10 years unless otherwise stated in the accompanying documentation.

The expected service life of the device battery is 5 years when the device is charged in accordance with these instructions for use, see 2.3. Charging.

In order to continue using the product beyond its expected service life, you must make sure that periodic maintenance at intervals no more than two years apart are performed until the device is permanently decommissioned. Maintenance should be carried out according to these instructions for use, see page 8. Servicing and reconditioning, in addition to the overall assessment below.

After the expected service life, Mercado Medic cannot guarantee the suitability and safety of the device, as Mercado Medic has no control over how the device has been used and its wear and tear. After the expected service life, Mercado Medic AB cannot guarantee the provision of spare parts.

Overall assessment

After the expected service life, it is important to make an overall assessment of the device before continuing to use it. The overall assessment of the device must be carried out by authorised personnel and should, as a minimum, take the following into consideration:

- how the device has been used,
- what condition the device and its components are in,
- whether the device has been reconditioned and serviced,
- when reconditioning and servicing have been carried out,
- what has been remedied on the above occasions,
- and the reason for the above remedial measures.

After the expected service life, periodic maintenance at intervals of a maximum of 2 years shall be carried out according to these instructions for use, see 8. Servicing and reconditioning, in addition to the overall assessment below.

6.4. Reporting of adverse events and incidents

As a manufacturer of medical devices in the EU, Mercado Medic is obliged to have a system to monitor how our devices work in practical use.

Before our devices are CE-marked and placed on the market, we have taken into account the risks that may be present with them and taken measures to reduce the risks as far as possible. Nevertheless, accidents and incidents can occur when the devices are used. If this happens, it is important that this is reported to both Mercado Medic and the national relevant authority. Use contact details in these instructions for use for reporting, see 1.1. Contact details. Feel free to use email to enable faster handling.

7. Technical information

This section describes the dimensions and performance of the device, as well as symbols that appear on the device.



Warning! Repairs and other technical measures may only be carried out by personnel authorised by Mercado Medic. If this is not followed, the CE marking no longer applies and Mercado Medic may no longer have full device liability.

User weight

Model	Max
REAL 8000 PLUS EL 24V Easy low	150 kg
REAL 8000 PLUS EL 24V Easy high	150 kg
REAL 8000 PLUS EL 24V Easy low extra	150 kg
REAL 8000 PLUS EL 24V Easy high extra	150 kg



Warning! The device must not be loaded with loads higher than the maximum user weight. At higher loads, there is a risk that the life of the device will be shortened and components may break. If the device has been subjected to higher loads than intended, authorised personnel should carry out an overall assessment, see 6.3 Expected service life, to ensure that it remains safe to use the device.

Device characteristics for all models

	REAL 8000 PLUS EL 24V Easy low	REAL 8000 PLUS EL 24V Easy high	REAL 8000 PLUS EL 24V Easy low extra	REAL 8000 PLUS EL 24V Easy high extra
Width ¹	430–480 mm			
Length	550 mm			
Total height ²	600–1030 mm			
Seat height ³	370–570 mm	450–730 mm	370–570 mm	450–730 mm
Seat width	290–480 mm			
Seat depth	320–530 mm			
Seat tilt ⁴	0°, -15°/+8°, -8°/+15°, 0°/+23°, -15°/+15°			
Backrest height	200–430 mm			
Backrest width	230–460 mm			
Backrest mechanism ⁴	0°, -15°/+30°, -15°/+45°, -23°/+28°			
Castors	Ø100 mm			
Weight	22–45 kg			
Maximum slope of surface in braked position ⁵	5°			

Device characteristics for all electric models

Battery	805320 Battery pack 2.6Ah 24V f RCB10+L
Battery type	Sealed valve-controlled lead acid battery
Voltage, battery pack	24V (2 x series coupled 12V batteries)
Charger	805265 Battery charger 9000 30V for work chairs 24V 1.5G

On a full charge with a high electrical lifting mechanism, you can raise the chair fully up/down a maximum of 180 times with a load of 80 kg, or up to 135 times with a load of 150 kg.

The electrical functions, except raising and lowering, may be used for max. 10% of the time (max. 2 mins/20 mins). The electronics measure activity and shut down the electrical functions if this limit is exceeded. When the total time of use in the last 20 minutes is less than 2 minutes, the features are automatically re-activated.

1 Depending on the seat width and the adjustment of the armrests, the device may become wider.

2 Total height with ErgoMedic backrest 380 x 260 mm.

3 These seat heights are achieved with different lifting mechanisms.

4 Negative angle (-) refers to forward tilt and positive angle (+) refers to backward tilt.

5 Applicable in all directions.

7.1. Symbols

The following symbols are used on the device controls, markings or in these instructions for use. For an overview of the location of symbols, see Figures 7.1–7.3.

No. Electric controls and control box

1		Battery level indication
2		Warning light
3		Seat height up/down
4		Seat tilt forwards/backwards
5		Back recliner forwards/backwards
6		Brake activation/deactivation
7		Charging socket
8		Input for control
9		Connection for electric lifting mechanism
10		Seat tilt connection
11		Connection for back recliner
12		Brake connection
13		Read the instructions for use before use

No. Labelling and instructions for use

14		Warning
15		Warning, crushing risk
16		Protect from moisture
17		Handle with care
18		This side up
19		Permitted temperature
20		Permitted relative humidity

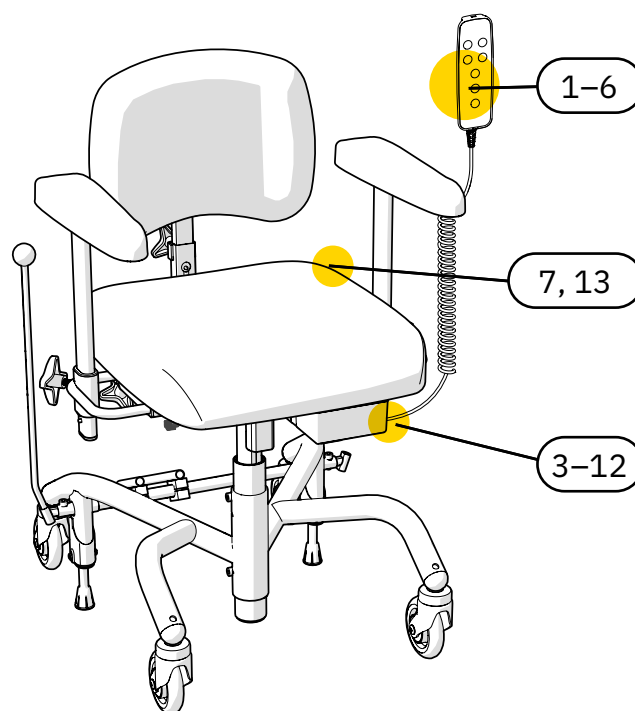

Figure 7.1. Overview of symbols on the device's controls.

No. Labelling and instructions for use

21		Permitted altitude
22		For indoor use only
23		Maximum user weight
24		Date of manufacture
25		Manufacturer
26		Medical device
27		Serial number
28		CE mark showing the device's conformity with the European regulatory framework
29		Device classified as Type B applied part according to IEC 60601-1:2005
30		Electrical components must be disposed of at a special collection point
31		The device is part of a recycling system
32		Component weight exceeds 10 kg
33		Operating cycle
34		Distributor
35		Directory number

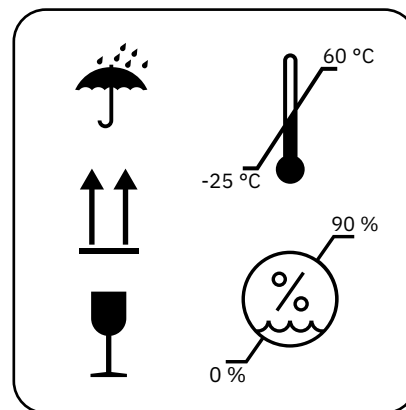

Figure 7.2. Overview of symbols on packaging. Symbols 16–20.

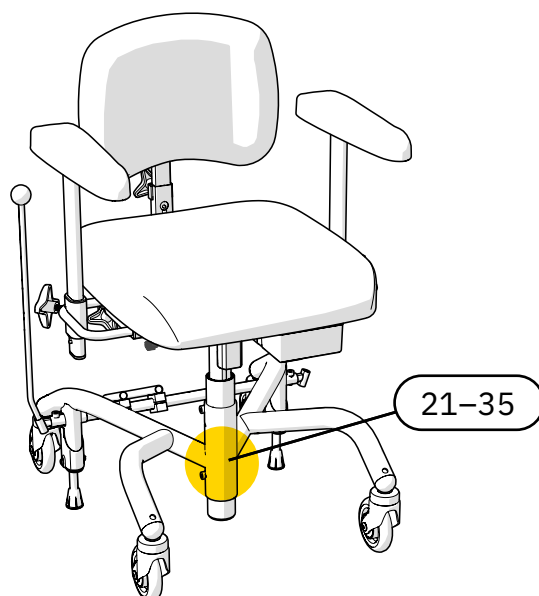

Figure 7.3. Overview of symbols on marking.

8. Servicing & reconditioning

This section describes the inspection and troubleshooting of the device, information about battery replacement and instructions for reconditioning the device. The troubleshooting guide is aimed at all users of the device, and the section is otherwise aimed at those who handle these parts of the device lifecycle professionally.

PLEASE NOTE! Reconditioning, servicing or maintenance work on the device is not permitted while the patient is sitting in it.

Inspection during service

A thorough visual inspection must be performed of the device's main components in order to guarantee the patient's safety. The main components of the device include base, brake, lifting mechanism, seat frame, back recliner and armrest mechanism. The inspection must include welds, lockable functions and settings.

When checking the PLUS base, always inspect the weld between the base's front and rear legs. Any indication of cracks in the material or paint in this area should be regarded as reason to replace the base, or the device. Make sure there is good lighting and preferably use a magnifying glass, as small cracks can be difficult to detect on black-painted bases.

In case of reduced braking action, check both the stability of the base and the condition of the brake rubber. If the device is not resting on all four wheels in the unbraked position, the device must be withdrawn from service immediately. Check the balance of the base in several locations and in several directions to exclude any influence from the floor.



Warning! Repairs and other technical measures may only be carried out by personnel authorised by Mercado Medic. If this is not followed, the CE marking no longer applies and Mercado Medic may no longer have full device liability.



Warning! As a user, you should contact your distributor if device performance deteriorates or changes. A device showing a loss of or change in performance must immediately be taken out of use in order to avoid an accident. The device must not be used again until an authorised technician has examined the device.

8.1. Troubleshooting guide

If none of the following actions address the problem that has occurred, service may be required. Contact your distributor or get in touch with Mercado Medic, see 1.1. Contact details.

Troubleshooting for electrical functions

Symptom	Cause	Action
The control box emits an audible signal.	The device has a low or critical battery level.	Charge the device, see 2.3. Charging.
The warning light is flashing on the controller.	The work cycle, that is, the maximum time an electrical function can be used before it needs to rest, is approaching its limit. See 7. Technical information for details.	Allow the device to recover; otherwise the device will shut down the current electrical function until the device has recovered.
The electrical functions do not work. The warning light flashes when a button is pressed, if the controller is in use.	The work cycle has been exceeded, see 7. Technical information. If the limit is exceeded, all electrical functions are switched off, except for electrical height adjustment. The features cannot be used again until the system has recovered.	The device will start working again once the system has recovered. This takes up to 20 minutes.
The warning light is flashing on the hand-held controller.	The button lock has been activated.	To enable or disable the button lock for a function, press and hold both of the directional buttons of the relevant function for at least three seconds. Each function has a separate button lock.
The warning light is flashing on the hand-held controller.	An internal error has occurred.	The system will be reset automatically after 10 seconds. If the error has been resolved, then all channels will be unlocked and the warning light will be switched off.
The electrical functions do not work. No hand-held controller is used, or the controller does not display a signal on the battery level indicator lights or warning.	The battery needs to be charged or activated. If the device has been unused for 7 days or more, the battery will be automatically disconnected to maximise service life.	Charge or activate the battery by connecting the charger. It is recommended to always charge fully when doing this. For activation only, it is enough that the charger is connected for about 5 seconds.

Symptom	Cause	Action
The electrical functions do not work. The indicator shows a low battery level if the controller is in use.	The internal batteries of the device are discharged or defective.	Charge the device, see 2.3. Charging. If charging does not fix the problem, a replacement battery is needed, see 8.2. Battery replacement.
Electrical functions do not work if a button on the wireless remote control is pressed.	The batteries in the wireless remote control are empty or defective.	Replace the batteries in the wireless remote control, see 8.2. Battery replacement.
Electrical functions do not work if a button on the wireless remote control is pressed.	The remote control and IR receiver are not properly paired.	Pair the remote control and receiver. See assembly instructions for Remote control IR 24B.
The electrical functions do not work.	Defective actuator.	If the above measures have not resolved the problem, this may be because the actuator is defective and needs to be replaced.

Troubleshooting mechanical components

Symptom	Cause	Action
The seat slips in the direction of rotation.	Gap in the lifting mechanism.	Replace the lifting mechanism.
Noise in the electric lifting mechanism.	Worn bearings.	Replace the electric lifting mechanism.
Noise in the castors.	Worn bearings.	Replace the castors.
The device does not move smoothly.	Accumulation of hair and debris in castors.	Clean the castors, see 3. Caring for the device. Alternatively, replace the castors.
The device does not move smoothly.	Worn bearings or uneven wheel track.	Replace the castors.
The device does not brake satisfactorily.	Accumulation of dirt and dust under brake feet.	Clean the underside of the brake feet, see 3. Caring for the device.
The device does not brake satisfactorily.	The rubber brake feet have solidified over time.	Replace the brake feet ¹ .
The device does not brake satisfactorily.	The base is warped and needs to be replaced.	Replace the base and report this event to Mercado Medic. See 1.1. Contact details.

¹ The brakes must be checked on a regular basis, see 6. Important safety information.

8.2. Battery replacement



Warning! Repairs and other technical measures may only be carried out by personnel authorised by Mercado Medic. If this is not followed, the CE marking no longer applies and Mercado Medic may no longer have full device liability.

The internal batteries of the device can be replaced. Both batteries in the battery pack must be replaced at the same time. For instructions, see installation instructions 'Battery replacement 24V'.

To replace batteries in remote control, see assembly instructions 'Remote control IR 24V'.

8.3. Reconditioning and periodic maintenance

No periodic maintenance is required during the expected service life of the device. In order to continue using the device beyond its expected service life, periodic maintenance at a maximum interval of two years apart must be performed until the device is permanently decommissioned.

Reconditioning in these instructions for use does not refer to a full restoration or complete refurbishment in the sense referred to in the Medical Devices Regulation (EU) 2017/745, MDR, with a view to putting the device on the market again with a renewed expected service life. Reconditioning in these instructions for use aims instead at a more comprehensive review and service of the device, but where serial numbers are retained and expected service life remains unaffected.

Inspection during reconditioning

Reconditioning must include a thorough visual inspection of the device’s main components in order to guarantee patient safety. The main components of the device include base, brake, lifting mechanism, seat frame, back recliner and armrest mechanism. The inspection must include welds, lockable functions and settings.

When checking the PLUS base, always inspect the weld between the base’s front and rear legs. Any indication of cracks in the material or paint in this area should be regarded as reason to replace the base, or the device. Make sure there is good lighting and preferably use a magnifying glass, as small cracks can be difficult to detect on black-painted bases.

In case of reduced braking action, check both the stability of the base and the condition of the brake rubber. If the device is not resting

on all four wheels in the unbraked position, the device must be withdrawn from service immediately. Check the balance of the base in several locations and in several directions to exclude any influence from the floor.

Replacement of components

On www.mercado.se there are various forms of substrate for changing components, such as exploded diagrams, assembly instructions, connection guides and digital item search. Installation instructions can also be used to disassemble the device's components. For accessories and spare parts please visit our webshop <https://shop.mercado.se/>.



Warning! Installation, connection or dismantling is not risk-free. If components are handled incorrectly, for example, crushing damage may occur. This type of work may therefore only be carried out by a Mercado Medic authorised technician.



Warning! All parts of the device must be installed and fixed so that there is no risk of small parts coming loose. All cables must be secured with cable ties to the device's structure to minimise the risk of strangulation.

Long-term storage of batteries

During longer periods of storage, the battery is automatically disconnected after seven days. The battery may also be forced into unplugged mode by plugging a 9V power supply (part number 804823) into the charging socket and waiting for at least 5 seconds before disconnecting the power supply. If the handheld controller is used, all of the indicator lights will flash when the battery is disconnected and the power supply can then be disconnected.

When the battery is disconnected, it must be charged every four months in order to retain its functionality, see 2.3. Charging. If these charging instructions are followed, the battery will maintain sufficient capacity for 5 years.

To reconnect the battery to the system again, connect the battery charger to the

charging outlet and wall socket. Wait at least five seconds before disconnecting the battery charger. The battery is now activated again and the system is ready for use. We recommend leaving the charger in place and fully charging the battery after the device has been stored with the battery in a disconnected state.

Reconditioning instructions

Do not use high pressure washers when cleaning the device. For instructions on everyday cleaning, see 3. Caring for the device.

The following points should be performed during reconditioning to ensure patient safety:

ID	Area	Reconditioning instructions
1 Cleaning		
1.1	Mechanisms	Clean mechanical parts (not the actuator) using a clean, damp cloth with mild detergent (pH 7-12), surface disinfectant or use a steam cleaner (max. 8 bar). PLEASE NOTE! Do not wash the device with water or other liquids and chemicals.
1.2	Electronics and cables	Remove dust with a dry cloth.
1.3	Controls, hand-held controller	Wipe the controls and hand-held controller with a cloth slightly dampened with disinfectant. This is so as not to pass on any possible infection.
1.4	Actuator and lifting mechanism	Moving parts are lubricated and should therefore not be cleaned. For lifting mechanisms, see special instructions under section 3.
1.5	Upholstery	We recommend dismantling and discarding all upholstery. Wash any covers according to the washing instructions.
1.6	Castors	Clear the castors of hair and dust.
2 Electrical components		
2.1	Electronics	Start by charging the device for at least 5 seconds to activate the electronics. Check the electronics and all electrical functions. Check for physical damage to the control box and any contact box.
2.2	Charger	Check that the charger is working and that the casing and cables are undamaged.
2.3	Controls	Make sure that the control buttons and controller are working and have no damage to the casing or cables.

ID	Area	Reconditioning instructions
2.4	Contacts	Check that cables and connectors are intact and properly secured. Ensure that all colour markings on contacts are still in place. Supplement if necessary. Check that there is no risk of crushing cables and connectors, and that all cables are fastened with cable ties.
2.5	Batteries	Check the batteries' voltage and that there is not too great a difference between the batteries' charge. A large difference in charging may indicate that a battery cell is defective. See installation instructions 'Battery replacement 24V'. Keep in mind that the life expectancy of the batteries is 5 years when maintained according to these instructions for use. This means that it may be time to replace them depending on when the reconditioning is complete and what remedial actions have been taken on the device in the past.
2.6	Electric seat tilt	Check that the actuator is not visibly damaged. Check the function of the actuator's moving parts. Check that all locking screws are tightened to avoid any play in the end position.
2.7	Electric back recliner	Check that the actuator is not visibly damaged. Check the function of the actuator's moving parts. Check that all locking screws are tightened to avoid any play in the end position.
2.8	Electric brake	Check that the actuator is not visibly damaged. Check the function of the actuator's moving parts. Check that all locking screws are tightened to avoid any play in the end position. Check that the attachments are intact and securely fixed to the base.
3 Electric lifting mechanism		
3.1	Noise	Listen for noise in the lifting mechanism. Replace the lifting mechanism in case of noise. Load the device and check that the lifting mechanism does not slip when starting from the bottom position. Defective lifting mechanisms can be sent to Mercado Medic for repair.
3.2	Rotation lock	Make sure that the lifting mechanism does not have any play when rotating or loading from side to side. Replace the lifting mechanism in case of play. Defective lifting mechanisms can be sent to Mercado Medic for repair.
3.3	Lifting columns	Raise the lifting mechanism to the highest position. Wipe the lifting column of dust and dirt with a dry cloth. Then lubricate the lifting column using a thin layer of Teflon or silicone-based grease.

ID	Area	Reconditioning instructions
3.4	Attachment	Check that the seat is facing straight ahead relative to the base. Check that the lifting mechanism attachments to the seat frame are correctly assembled and tightened. Replace screws that have damaged key handles or threads.
3.5	Cabling	Inspect cables for any signs of wear, pinching or crushing.
4 Base		
4.1	Welds	Check all welds carefully for signs of cracks, corrosion and movement. Make sure there is good lighting and preferably use a magnifying glass, as small cracks can be difficult to detect on black-painted bases. Make sure the base is stable. Fill in any varnish damage with touch-up paint to avoid corrosion.
4.2	Bolted joints	Check and tighten all screw joints. Replace screws that have damaged key handles or threads.
5 Brakes		
5.1	Function	Replace the brake feet. Check that the brake is working properly.
5.2	Plastic plugs	Check that guide bushings and plastic plugs are properly secured. Replace worn or damaged parts.
5.3	Pinch protection	Check that any pinch protection is securely mounted. If there is no pinch protection on the brake legs, it is recommended that this be installed before the device is put back into service.
6 Castors		
6.1	Function	Check castors and jumpers for wear or play. Wear or play may indicate defective bearings. Check that the castors rotate well and the housings rotate. Replace worn or damaged parts.
6.2	Attachment	Check that the castors' screws are intact and tightened. Replace screws that have damaged key handles or threads.
7 Seat frame		
7.1	Mechanics	Carefully check all welded parts for cracks and paint damage. In particular, check around the mounting of actuators for the seat tilt and at the holes for mounting leg supports, as these areas are particularly subject to load. Ensure good lighting and preferably use a magnifying glass, as small cracks can be difficult to detect on black lacquered structures. Fill in any varnish damage with touch-up paint to avoid corrosion.

ID	Area	Reconditioning instructions
7.2	Bolted joints	Check and tighten all screw joints. Replace screws that have damaged key handles or threads.
7.3	Plastic plugs	Check that guide bushings and plastic plugs are properly secured. Replace worn or damaged parts.
7.4	Controls	Make sure that all knobs and handles on the seat frame are working and that they lock correctly.
8 Back rest mechanism		
8.1	Mechanics	Check and replace any worn parts, carefully inspect for cracks in welds as they may have been heavily loaded for a long time. Ensure good lighting and preferably use a magnifying glass, as small cracks can be difficult to detect on black lacquered structures. Check that the moving parts work properly.
8.2	Attachment	Make sure that all screws, knobs and handles are easy to move and lock properly. Check that the spring button clips are working flawlessly.
8.3	Plastic plugs	Check that guide bushings and plastic plugs are properly secured. Replace worn or damaged parts.
9 Armrests		
9.1	U-bars	Carefully check the U-bars for cracks and paint damage. Check especially around welds and grooves for the locking, as these areas are particularly subject to load. Ensure good lighting and preferably use a magnifying glass, as small cracks can be difficult to detect on black lacquered structures. Fill in any varnish damage with touch-up paint to avoid corrosion.
9.2	Function	Check and replace any worn parts. Test that locking and function in moving parts are working properly. Check that knobs and screws are working and have no damage to threads or grip surfaces.
9.3	Plastic plugs	Check that guide bushings and plastic plugs are properly secured. Replace worn or damaged parts.
9.4	Armrest mechanics	Check all welds and that there is no damage to mechanical parts that may impair or weaken the structure. Ensure good lighting and preferably use a magnifying glass, as small cracks can be difficult to detect on black lacquered structures. Fill in any varnish damage with touch-up paint to avoid corrosion.

ID	Area	Reconditioning instructions
10 Accessories		
10.1	Restoration	Remove the accessories that should not be attached to the device in the basic version, see 5.2. Basic design.
10.2	Mechanics	Check all welds and that there is no damage to mechanical parts that may impair or weaken the structure. Ensure good lighting and preferably use a magnifying glass, as small cracks can be difficult to detect on black lacquered structures.
10.3	Function	Check and replace any worn parts. Check that the locking and function of moving parts works properly.
11 Final inspection		
11.1	Final inspection	Test all functions of the device. Check that all settings, electrical functions and brakes are working properly. Check that the castors are working properly and that all four wheels are in contact with the surface.
11.2	Battery sleep mode	If electrical models are to be stocked, the battery can be put into sleep mode with the intended 9V adapter, see 8.3. Reconditioning and periodic maintenance, Long-term storage of batteries.

9. Instructions for destruction

Devices permanently decommissioned must be dismantled and sorted in a correct and safe manner. At the website www.mercado.se there are installation instructions that can also be used to dismantle the device's components. The components should then be discarded in the relevant manner, see 9.1. Recycling sorting.



Warning! Installation, connection or dismantling is not risk-free. If components are handled incorrectly, for example, crushing damage may occur. This type of work may therefore only be carried out by a Mercado Medic authorised technician.

9.1. Recycling

Instructions for recycling of components.

Metal

- Armrest mechanism
- Backrest mechanism
- Neck support mechanism
- Leg support
- Base
- Seat frame
- Actuator
- Lifting mechanism
- Other metal parts in devices sold by Mercado Medic

Electronics

- Cabling
 - Control box (batteries to be dismantled and recycled separately)
 - Contact box
 - Hand-held controller
 - Control buttons
- Lead battery**
- Batteries (discarded batteries should always be taken to environmental recycling centres)

Combustible

- Seat
- Backrest
- Neck support
- Armrests
- Other padded parts sold by Mercado Medic

