



# ⊕ REAL® 6100 PLUS



## INSTRUCTIONS FOR USE AND MAINTENANCE REAL 6100 PLUS with DX/DX2 control unit

Doc.no. 20-07458-UK-02  
Amended 2020-12-04  
Valid from 2011-12-01

The REAL 6100 PLUS is a Class I medical device. It is CE marked in accordance with the Swedish Medical Products Agency's code of statutes for medical devices, LVFS 2003:11, and has been tested and approved in accordance with EN 12184, Class A. All textiles used for the chair have been tested and approved in accordance with EN 1021-1 and EN 1021-2. Mercado Medic AB is certified to ISO 9001, ISO 14001 and ISO 13485 and complies with applicable labour and environmental legislation.

If you have any questions about your product or if something unexpected has happened, please contact your dealer first, otherwise you are welcome to contact us at Mercado Medic AB.

PDF versions of our instructions for use and care with magnification options can be found on our website: [www.mercado.se](http://www.mercado.se). Information is also provided on the website about accessories that can be installed on Mercado Medic's chairs, as well as any field safety notices, prescribing support or recalls of products and accessories.

We reserve the right to make changes to this manual and its contents.

### TABLE OF CONTENTS

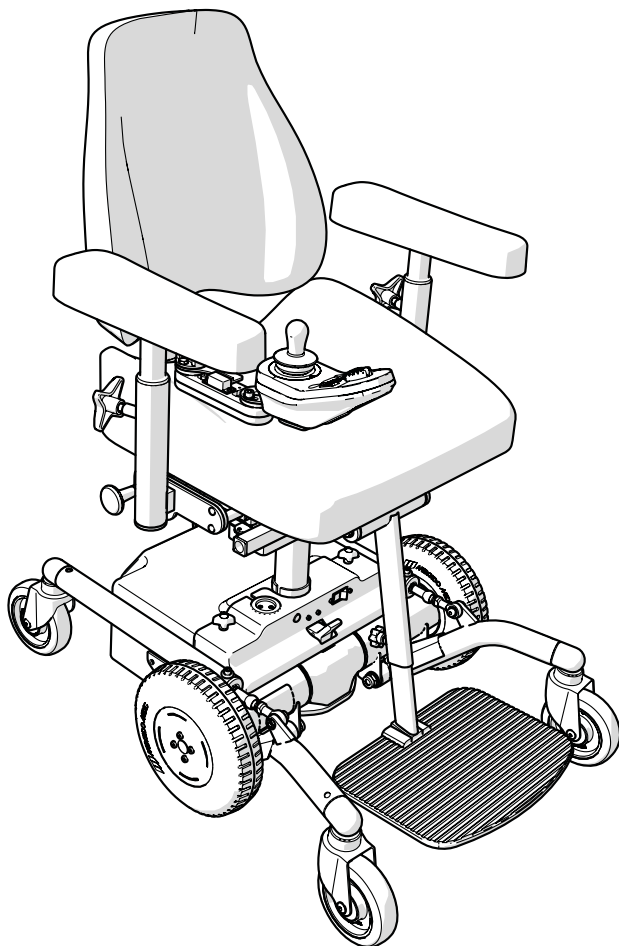

Important information . . . . .	3
Expected service life . . . . .	3
Checkpoints before operation . . . . .	4
Storage, cleaning and maintenance. . . . .	4
Technical information and measurements for REAL 6100 PLUS . . . . .	4
Transfers . . . . .	5
<input type="checkbox"/> DX-REMG90A control unit . . . . .	11
<input type="checkbox"/> Control unit DX2-REM421 . . . . .	12
<input type="checkbox"/> Control unit DX2-REM550 . . . . .	13
Charging. . . . .	14
Service and troubleshooting of control unit DX/DX2 . . . . .	15
Troubleshooting & actions for DX/DX2 . . . . .	16
Service and troubleshooting of REAL 6100 PLUS . . . . .	17
Programming schedule . . . . .	17
Checklist reconditioning and service REAL 6100 PLUS . . . . .	18
Instructions for destruction. . . . .	19
Guidelines for individual customisations of Mercado Medic AB products . . . . .	20

**Sufficient competence in the safe use of this product is achieved by carefully reading through these instructions for use and care before using the chair for the first time.**



## IMPORTANT INFORMATION

The REAL 6100 PLUS has exchangeable components, accessories and functions with setting options for individual adaptation. The chair may only be used by the person for whom, and for the purpose for which, it is intended.

The chair is intended for indoor use only and must not be used outdoors. The chair must not be exposed to excessive cold, excessive heat, prolonged sunlight or other forms of radiation. The chair must also not be exposed to water, other liquids or chemicals.

Warning! Metal surfaces may become very hot if they are exposed to direct sunlight. The chair must not be equipped with any accessories or components other than those approved by Mercado Medic AB. Repairs and other technical measures may only be carried out by personnel authorised by Mercado Medic AB.

- The REAL 6100 PLUS is a Class A product and is intended for indoor use only.
- Maximum user weight: 135 kg. When customising the product for heavier users, please contact Mercado Medic AB.
- Driving programs must be adapted for the user so that the chair can be operated in a safe manner with regard to the user and the user's surroundings. Only authorised personnel may perform driving program customisation.
- The REAL 6100 PLUS must not be equipped with any accessories or components other than those approved by Mercado Medic AB.
- The warranty period is two (2) years unless otherwise agreed. For warranty issues, please contact Mercado Medic AB. For warranty cases, please contact Mercado Medic AB.
- Maximum service life is ten (10) years.
- Repairs and other technical measures may only be carried out by personnel authorised by Mercado Medic AB.
- Chairs with an adjustable seat tilt must be in a fixed position when transferring to or from the chair.
- The REAL 6100 PLUS must not be operated when the seat is in the raised position. If the seat is raised, the obstacle-climbing capability may be reduced as the chair runs more slowly and less power reaches the drive wheels. To climb obstacles safely, drive the chair at the lowest possible seat height.
- The REAL 6100 PLUS comes with a backrest, seat and leg support as standard.
- The chair is approved for all types of transport.
- The automatic fuse must be switched off during transport.
- This symbol warns of the risk of crushing and of positions/situations where we indicate there are risks: 
- If the REAL 6100 PLUS is equipped with leg supports, the user's feet must remain on the footplate when electrical functions are being used.
- Exercise care when lifting the battery pack as it is heavy and can cause contusions if dropped. Be careful when lifting the battery pack as it is heavy and can cause crush injuries if dropped.
- During servicing, always reinstall the battery terminal protective cover. The absence of the protective cover may result in personal injury on the occasion of a later service.
- Do not allow small children to be in the vicinity of the product unsupervised. The cover plug on the front cover poses a choking hazard for small children. Please see section on Your REAL 6100 PLUS for reference.

## EXPECTED SERVICE LIFE

The expected service life of the Product is ten years when used in accordance with the instructions in this manual. The Product's date of manufacture can be found together with the serial number on one of the silver labels on the Product's chassis, marked with Lev/Del and stated in the format YYWW (number of year and week).

As a user of the Product, you should contact your prescriber, technical aids centre or distributor if the Product shows reduced or altered performance.

After the expected service life, it is important to make an overall assessment of the Product before continuing to use it. After the expected service life, Mercado Medic AB cannot guarantee the suitability and safety of the product, as Mercado Medic AB has no control over how the product has been used and wear and tear. The overall assessment of the Product should be carried out by the healthcare organisation if the product is prescribed, and, as a minimum, should take into account how the Product has been used, the condition of the Product and its component parts, whether the Product has been reconditioned and been serviced, when this occurred, what actions have been taken on these occasions and the reason for the actions.

In markets outside Sweden and Norway where a distributor has sold the Product directly to the user (where applicable), and therefore there is no responsible prescriber, periodic maintenance must be carried out according to instructions in the section Reconditioning and Service in addition to the overall assessment above.

After the expected service life, Mercado Medic AB cannot guarantee the provision of spare parts. CE marking is not affected by expected service life.

## CHECKPOINTS BEFORE OPERATION

- All knobs and locking levers must be tightened on the chair before driving. If play or other deviations are detected, report this to the responsible technical aids centre.
- The leg support should not be adjusted so that it is in contact with the floor or other such surfaces.
- A belt and similar equipment should be handled in such a way that it cannot become entangled or get caught in other parts of the chair.
- Fold the armrests up.
- Fold the footplate down.
- Install the backrest support post.

## INSPECTING THE CONTROL UNIT

- Turn on the main switch.
- The battery level indicator should not be down to the red marking.
- The display must not indicate an error (see *Troubleshooting and actions for DX/DX2* on how to handle error signals).



Do not operate the chair with the backrest, footplate and/or armrests removed.

## STORAGE, CLEANING AND MAINTENANCE

**Service intervals:** No preventive maintenance is necessary.

Store the chair in a dry environment at room temperature. Check the battery charge level before use. If the chair is to be stored for more than one month, disconnect the battery fuse. The chair is designed for indoor use and must not be rinsed with water, other fluids or chemicals. The chair can be cleaned/wiped clean with surface disinfectants. We approve the use of detergents with a pH ranging from 7 to a maximum of 12 (concentrated). The chair must not be exposed to extreme heat, prolonged and intense sunlight or other radiation. If the chair has been transported in extreme cold, it must be allowed to reach room temperature before use. The chair should be wiped down and kept free from dust and dirt.

**Wash plush upholstery** with a foam wash;

1. Remove any dirt, crumbs and similar.
2. Apply a thin layer of foam and rub the foam in evenly with a

damp cloth.

3. Wipe with a clean and lightly dampened cloth.
4. Vacuum well once everything has dried.

**Artificial leather** should be washed with soapy water alternatively wiped down with an alcohol solution, e.g. a disinfectant.

Do not use any other cleaning agents.

For functional reasons, seats, backrests and other padded parts are not made from impermeable materials. Padded parts should be replaced during reconditioning for hygienic reasons.

The electric lifting mechanism should be checked regularly for dust, dirt and stability: Raise the seat to its highest position. Clean with a cloth. Do not use water or any type of solvent. Then lubricate the cylinder with a thin layer of Teflon or silicon-based grease. Use a suitable touch-up paint for colour improvement. This is available from Mercado Medic AB.

## TECHNICAL INFORMATION AND MEASUREMENTS FOR REAL 6100 PLUS

### TECHNICAL INFORMATION

Maximum user weight	135 kg
Drive wheels	both centre wheels
Driving distance per charge	approx. 15 km*
Weight	76 kg incl. battery
Motors	ME803661C Allied Motion Stockholm AB
Charging time	approx. 6–8 hours
Chargers tested and approved by Mercado Medic AB	ECB-401 Easy Buddy 4A
Batteries tested and approved by Mercado Medic AB	FGS, FGG22805, 2 pcs 12V 28 Ah

### STANDARD DIMENSIONS

Total width	570 mm
Length	795 mm
Collapsed height	550 mm
Static stability	+6°/-6°**
Static lateral stability	6°
Dynamic stability	upward gradient 10°, downward gradient 3° ***
Obstacle-negotiating capability	40 mm

### STANDARD DIMENSIONS, CONTINUED

Maximum speed	4.5 km/h
Braking distance from max. speed	1.0 m/0.7 m active brake
Seat tilt	-15°/+8°, -8°/+15°, 0°/+23°
Seat depth	170–540 mm
Seat width	290–550 mm
Seat height	460–740, 380–580 mm****
Backrest angle	-15/+45°
Backrest height	390–650 mm
Leg support length	370–530 mm
Leg support angle	0°/+32°
Armrest height	150–300 mm
Backrest-armrest mech.	100–250 mm
Turning space 180°	870 mm
Front/rear wheels	Ø 125 mm (article no. 804362)
Drive wheels	Ø 225 mm (article no. 805203)



\* In optimal driving conditions.

\*\* Seat tilt and backrest tilt settings together with a high seat height can affect both static and dynamic stability.

\*\*\* The chair should be reversed down greater downward gradients.

\*\*\*\* Measured from floor to the underside of the seat, with the potential for continuous downward adjustment to a max. 3 cm.

# TRANSFERS

## TRANSFERRING TO AND FROM THE CHAIR

**Please note:** Always consult your prescriber for advice on the most suitable technique for transferring to and from the wheelchair, from the front or the side. What best suits you and your needs and thus minimises the risk of injury.

**WARNING!** Only transfer to and from the chair on a flat surface. Position the chair correctly for the transfer and adjust the seat height to the correct position.

**WARNING!** At the time of the transfer to prevent the chair from moving unexpectedly, make sure that the control unit is switched off and that the brake is engaged.

## TRANSFERS FROM THE SIDE

When transferring to the chair from the side, you must aim to ensure that the seat of the chair is positioned somewhat lower than the position you are transferring from. When transferring from the chair you can raise the chair so that you are sitting positioned somewhat higher than the position you are transferring to. Remember to only fold away or lower the armrest of the chair on the side you are transferring over.

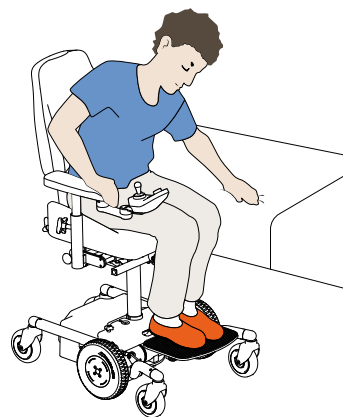

## TRANSFERS FROM THE FRONT

When transferring to the chair from the front, you must aim to ensure that the front edge of the seat is no higher than knee level; this is so you can sit well back into the seat without having to make further adjustments. Remember to fold away or lower the footplate so you can get close to the seat. If you are using a lift to transfer to and from the chair, you must bear in mind any crushing risk. Make sure that hands, feet and any items of clothing cannot get in the way and risk injury.

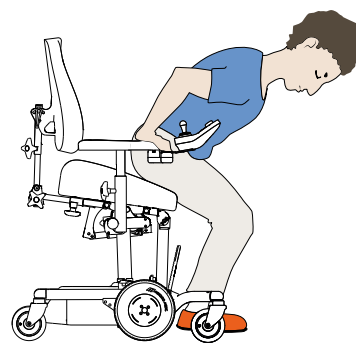

## RAMPS

**WARNING!** Before driving on a ramp, check that it can withstand the total weight of you and your electric wheelchair. To increase the stability of the chair when driving on a ramp, lower the seat lift and level the seat tilt. When driving down a ramp, we recommend always reversing the chair. If the down gradient exceeds 3 degrees, the chair should be reversed down the ramp.

Always drive straight up the ramp from the front, not obliquely.

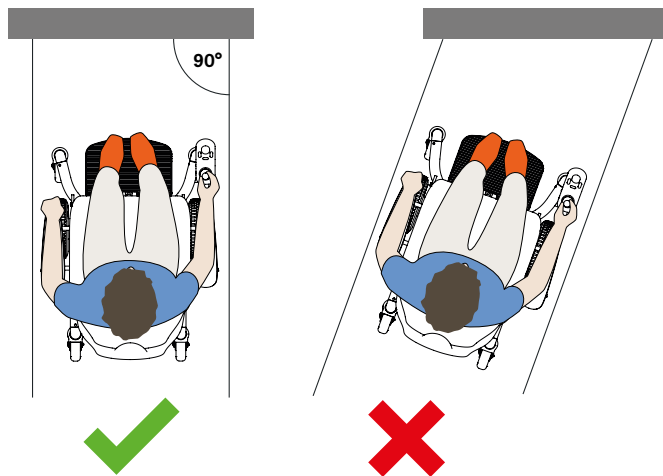

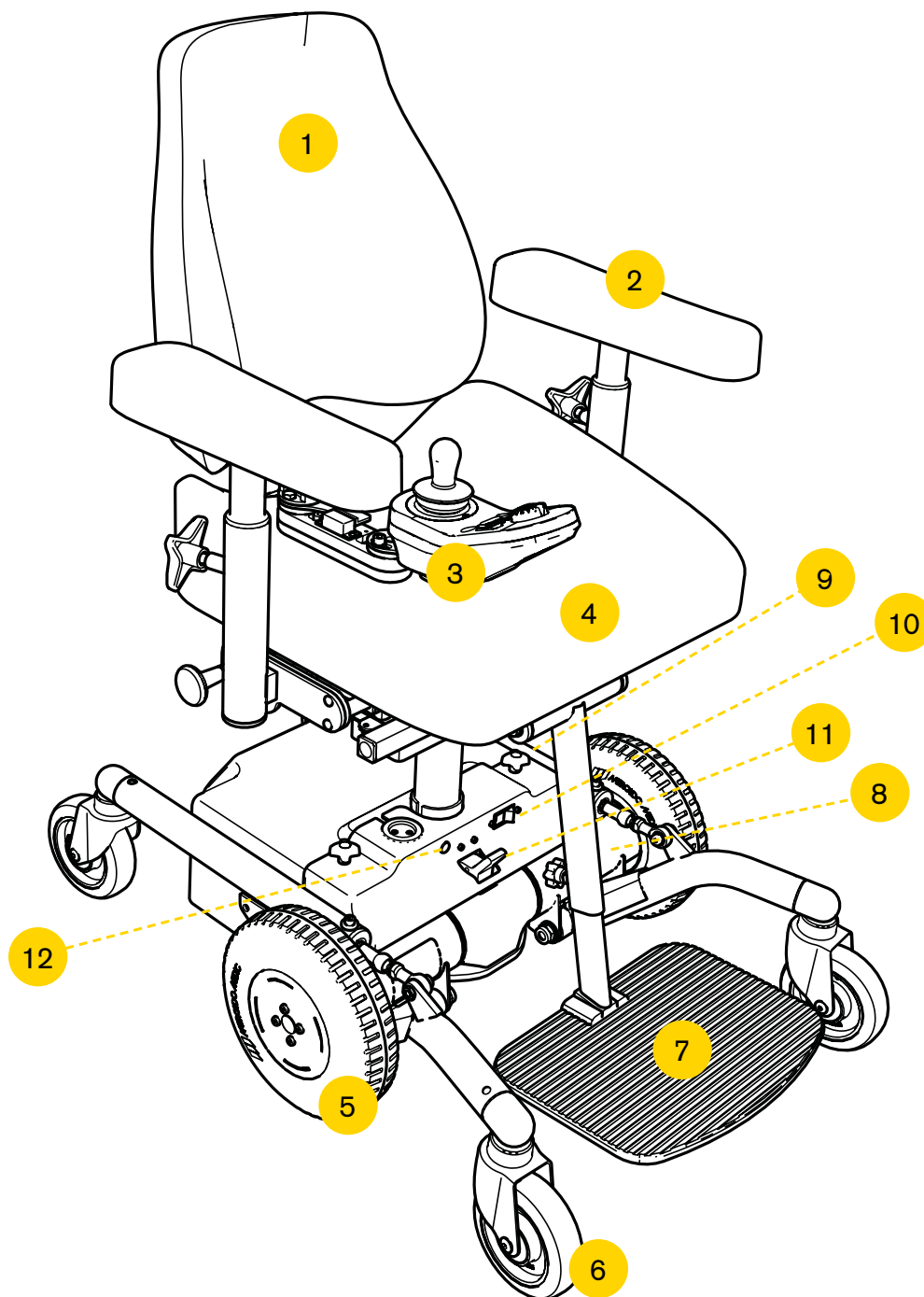

1. Backrest adjustable in height, angle and depth.
2. Armrests adjustable in width and height.
3. Control unit (also controls electrical seat functions).
4. Seat adjustable in height. Seat tilt is available as an accessory.
5. Drive wheels, puncture free.
6. Castors with individual wheel suspension.
7. Footplate adjustable in height and angle.
8. Label with unique serial number.
9. Warning label with transport information.
10. Automatic fuse with On/Off function. Also used to disconnect the batteries, e.g. when the chair is to be transported by air.
11. Brake release controls.
12. Cover plug on front cover (see risk description under *Important information*).

## ARMRESTS

The user can adjust the height and width of the armrests. If the chair has foldable armrests, these can also be folded backwards.

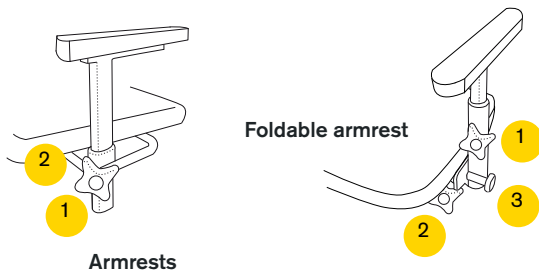

## CONTROLS

1. Height. To adjust the height of an armrest, loosen the knob (1). Pull/press the armrest to the desired height. Then tighten the knob.
2. Width. To adjust the width, loosen the locking mechanism, knob or screw\* (2). Pull/press the armrest to the desired width. Then tighten the locking mechanism.
3. Folding. To fold the armrest, pull out the pin and turn through 90° (3). This releases the fold function. Then fold the armrest backwards.

\* The lock screw key is delivered with your chair and is mounted on the back of the backrest.



**NOTE!** Remember to turn the pin back again after folding up the armrest to ensure that the fold function is locked.

## INSTALLING THE BACKREST

Insert the backrest support post (1) into the backrest mechanism (2) while depressing the snap lock (3). Adjust to the appropriate height (see section on *Backrest mechanisms* for instruction on how to adjust the backrest). Lock the backrest support post using the knob (4). Perform dismantling in the reverse order.

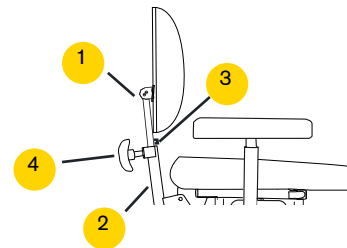

## BACKREST MECHANISMS

 Adjust the backrest so that the user's calf is at a distance of about 2–3 cm from the front edge of the seat while in a sitting position. This is to promote blood circulation while maintaining a stable sitting position when operating the chair.

*The standard* backrest mechanism can be adjusted in height, depth and angle, and is available with both high and low backrests.

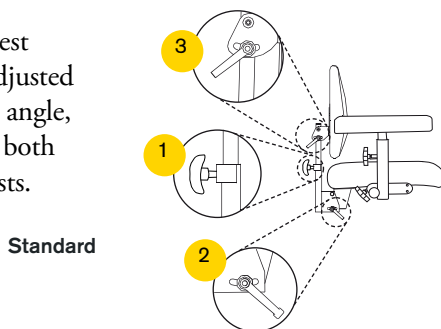

Standard

In addition to height, depth and angle adjustments, the *Medic* backrest mechanism (option) has an extended depth adjustment option.

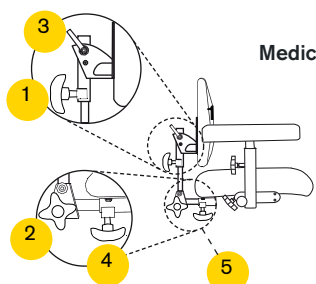

Medic

## THERE ARE FOUR TYPES OF BACKREST MECHANISMS:

Standard, Medic, Comfort and Electric. All are available in a low respectively high design (all illustrated chairs have low backrests). All backrest mechanisms have separate controls for height, depth and angle. The Medic model has an extended depth adjustment.

## CONTROLS STANDARD

1. Height. Loosen the knob (1) to adjust the height of the backrest. Press or pull the backrest to the desired height.
2. Backrest mechanism angle. Loosen the lever (2) to adjust the angle of the backrest mechanism. Then place the backrest mechanism at the desired angle and tighten the lever.
3. Backrest angle. To adjust the angle of the backrest, loosen the lever (3). Then place the backrest at the desired angle and tighten the lever.

## CONTROLS MEDIC

1. Height. Loosen the knob (1) to adjust the height of the backrest. Press or pull the backrest to the desired height. Then tighten the knob.
2. Backrest mechanism angle. Loosen the knob (2) to adjust the angle of the backrest mechanism. Then place the backrest mechanism at the desired angle and tighten the knob.
3. Backrest angle. To adjust the angle of the backrest, loosen the lever (3). Then place the backrest at the desired angle and tighten the lever.
4. Depth. Loosen the knob (4) to adjust the depth of the backrest mechanism. Then pull or push the backrest mechanism to the desired depth. Then tighten the knob.
5. Button clip. When adjusting the depth of the backrest mechanism, ensure that the button clip locks and that the backrest mechanism cannot be pulled out.

## CONTINUATION BACKREST MECHANISMS

The **Comfort** backrest mechanism (option) looks and works like a Medic backrest mechanism without depth adjustment, and the angle adjustment of the backrest mechanism is operated using the handle on the gas spring (2).

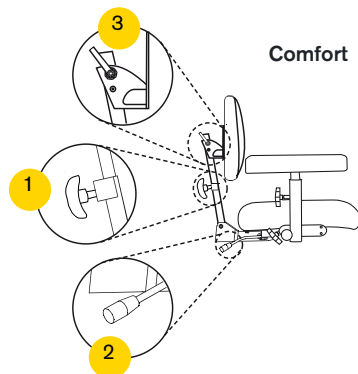

### CONTROLS COMFORT

1. Height. Loosen the knob (1) to adjust the height of the backrest. Press or pull the backrest to the desired height. Then tighten the knob.
2. Backrest mechanism angle. To adjust the angle of the backrest mechanism, use the handle on the gas spring (2). Then place the backrest mechanism at the desired angle and release the handle.
3. Backrest angle. To adjust the angle of the backrest, loosen the lever (3). Then place the backrest at the desired angle and tighten the lever.

The **EL** backrest mechanism can be adjusted in height, depth and angle, and is available with both high and low backrests. The backrest mechanism can be set in two different angle adjustment ranges.

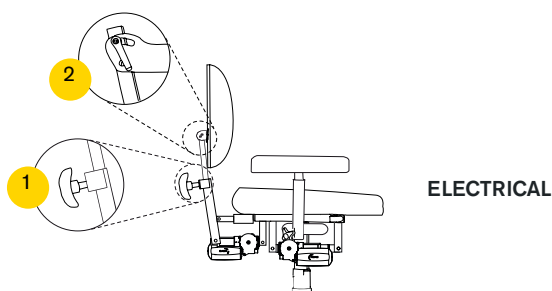

### CONTROLS ELECTRICAL

1. Height. To adjust the height of the backrest, loosen the knob (1). Press or pull the backrest to the desired height.
2. Backrest angle. Loosen the lever (3) to adjust the angle of the backrest. Then place the backrest at the desired angle and tighten the lever.
3. Backrest mechanism angle. The angle of the backrest mechanism is adjusted from the control unit.

## TRANSPORT IN VEHICLE

When transporting the REAL 6100 PLUS by car, the user must transfer to the vehicle seat. During transport, the chair must be equipped with transport loops and must be secured using the tension straps on the transport vehicle. Also switch off the automatic fuse by pressing OFF. If the fuse has tripped, it must be reset by pressing ON. The control unit must be restarted two (2) times in order to reset the chair's functions. Transport loops are an accessory that can be ordered using article number TR1010.



The chair is not suitable for sitting in during transport.

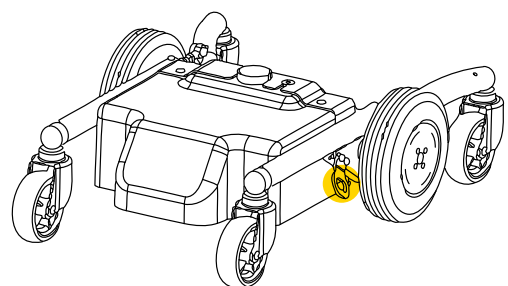



## SEAT TILT

### THERE ARE THREE TYPES OF SEAT TILT:

Gas spring, crank-operated and electric tilt.

The gas spring control is located under one of the armrests (1) or under the right rear edge of the seat (2), and is adjusted by carefully moving the lever forward. Crank-controlled seat tilt is operated with a crank (3). The range of the seat tilt can be limited with the nuts (4).

The electric seat tilt (5) is adjusted using the control unit. See section *Control unit*.

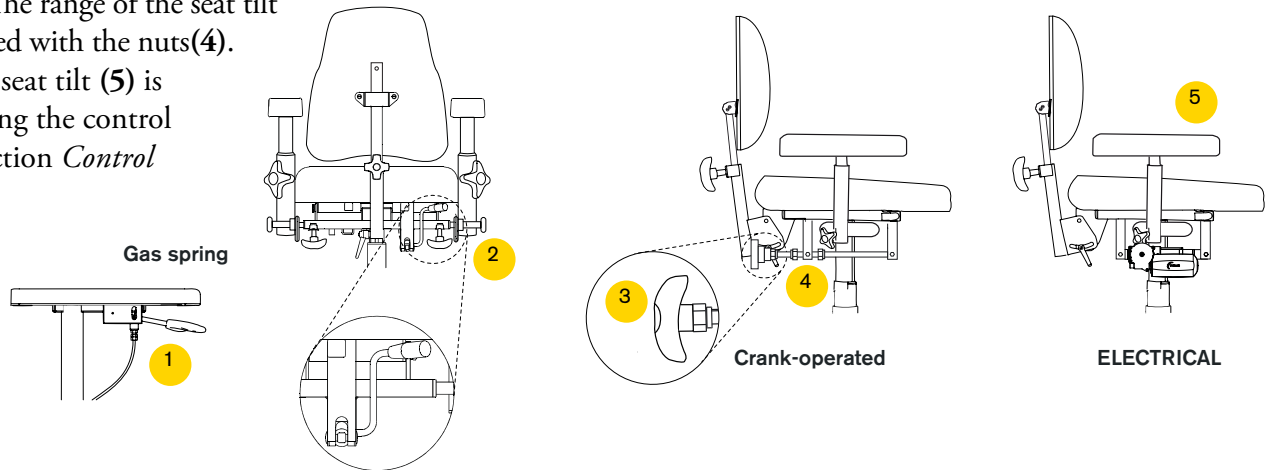

### CONTROLS

1. Gas spring under armrest.
2. Gas spring under seat.
3. Crank-operated under seat.
4. Nuts on crank-operated tilt.
5. Electrically adjusted – see section on *Control unit*.

## SEAT FRAME -15/+23° (OPTIONAL)

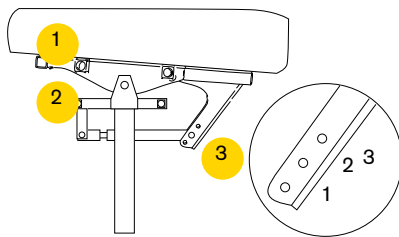

### CONTROLS

1. Armrest placed here follows the seat tilt.
2. Armrest placed here does not follow the seat tilt.
3. There are 3 positions. **If using position 3, the chair must be equipped with base extenders.**
  1. Forward 15°, backward 8° – Standard seat tilt
  2. Forward 8°, backward 15° – Reversed seat tilt
  3. Forward 0°, backward 23° – Backward seat tilt only

## ADJUSTING THE POSITION OF THE CONTROL UNIT

The control unit can be adjusted in depth and sideways. To adjust the depth, remove the screw (1) using a 5 mm Allen key and a 10 mm ring spanner. Move the control arm to the desired position (three possible positions) and then refit the screw. The control unit can be moved to both the inside and the outside of the armrest.

The control arm is articulated at two points, allowing horizontal lateral movement of the control unit without using tools. Move the control unit to the desired position. The control unit can be placed on the right (standard) or left armrest.

### WITH A PARALLELOGRAM

A magnetic attachment allows for easy adjustment parallel to the armrest. Adjust positions with screw (1) then lock screw. Move the control unit to the desired position and release.

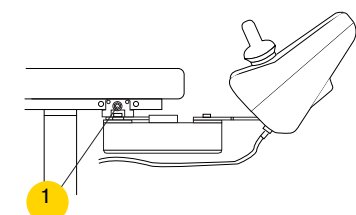
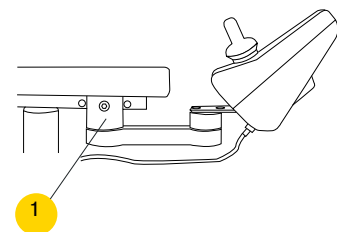

## FOOTPLATE

The height and the angle of the footplate can be adjusted.

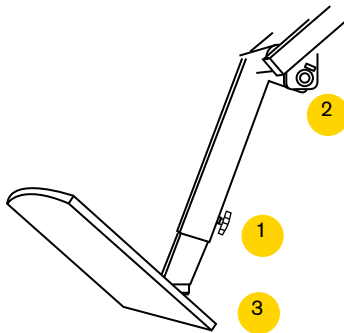

## CONTROLS

1. Height. Loosen the knob (1) to adjust the height of the footplate. Then pull or push the footplate to the desired height\*.
2. Leg support angle. The angle of the leg support can be adjusted to four different positions. To adjust the angle, unscrew the screw (2) using a 5 mm Allen key. Set the desired angle and retighten the screw.
3. Footplate angle. To adjust the angle of the footplate, adjust the screw (3) using a 5 mm Allen key. To lower, turn the screw clockwise. To raise, turn the screw anti-clockwise.

\* Make sure that you properly insert the knob into one of the holes in the footplate tube. This is to ensure that the footplate does not come loose.



**NOTE!** Crush hazard for feet between footplate and floor. Make sure that your feet remain on the footplate during operation.

## DISENGAGING THE BRAKE

Disengaging the brake allows the user to move the chair manually. To disengage, pull the control towards you (1), downwards in the illustration on the right. To re-engage the brake, push the control back to its original position. If the chair disengages while it is on-mode, the control panel will display an alarm rendering the chair inoperable. Re-engaging the brake will cause the alarm to disappear and the chair will be operational again.



**NOTE!** The chair must never be transported in vehicles with the brake disengaged.

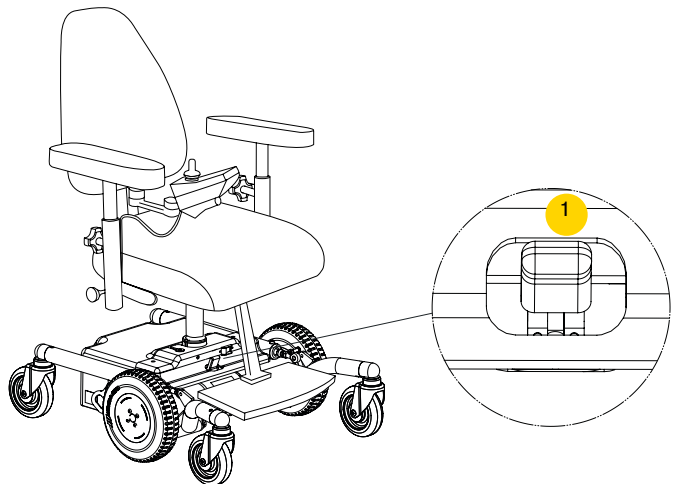

## PROGRAMMING UNIT

Only authorised personnel may perform driving program customisation.

### Selection of programmable functions:

- Forward speed
- Forward acceleration
- Forward braking distance
- Reverse speed
- Acceleration backwards
- Reverse braking distance
- Turning speed
- Turning acceleration
- Turning deceleration
- Joystick sensitivity
- Use of external joystick
- Reverse joystick function



Driving programs must be adapted for the user so that the chair can be operated in a safe manner with regard to the user and the user's surroundings.

# DX-REMG90A CONTROL UNIT

## Manoeuvring Driving

Turn on the main switch (1). Check the battery level (4). The battery level should not be down to the red marking. Check that the control unit is not generating an error signal (10).

Runtime: Check that the display (3) is displaying one of the drive programs. Press the drive program buttons (2) until the desired program is displayed. If not, press the function button (2) until one of these digits is displayed.

Move the joystick (5) straight ahead for forward movement and obliquely to the left/right to turn. The chair can be rotated by moving the joystick (5) straight to the left/right.

To brake, release the joystick (5) so that it comes to rest in the neutral position (in the centre), or pull the joystick in the direction opposite to the direction of travel for faster braking. Remember that the braking distance is affected by the slope of the surface underneath the chair.

Downhill = longer braking distance



Uphill = shorter braking distance

To reverse, pull the joystick (5) backwards.

## OPERATION OF SEAT UNIT

For raising/lowering the seat unit or the electric seat tilt/backrest angle or leg support angle. Press the option button (6). The electrical functions mounted on the chair are lit on the options display (7); the active electrical function flashes. Move the joystick to the right/left to switch between the symbols in the options display and forward/backward to operate the different options.

## CONTROL – SYMBOLS

-  Seat height
-  Seat tilt
-  Backrest angle
-  Leg support angle

The two leg support angles can be controlled at the same time when both symbols for the left/right leg support angle are flashing simultaneously. When the chair's electrical function has not been used for five minutes it will automatically shut down to save battery power. To start the electronics, press the main switch (1) or touch the joystick (5). The time interval for automatic shutdown is adjustable. Horn: press button (8).

## LOCK FUNCTION

Use the magnetic key (9) to lock the electronics. The electronics must be switched on using the main power switch (1) during locking/unlocking. Hold the magnetic key (9) against the key symbol (10) to lock/unlock. During locking, the control panel is completely switched off and the key symbol flashes red; turn on the main switch (1) to unlock. When the chair is locked (and turned on), the red light in the key symbol (10), will flash; repeat this procedure with the Magnetic Key (9). The buttons (11) have not been programmed for any function. 

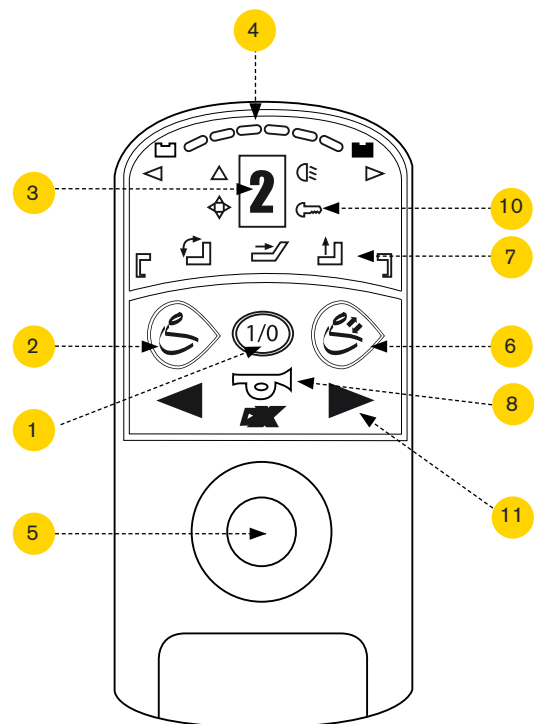

DX-REMG90A control unit

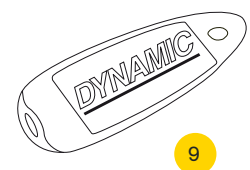

## OPERATION DRIVING

Turn on the main switch (1). Check the battery level (4). The battery level should not be down to the red marking. Check that the control unit is not generating an error signal (9).

Runtime: Make sure that the display (3) is displaying one of the drive programs. Press the drive program buttons (2) until the desired program is displayed.

Move the joystick (5) straight ahead for forward movement and obliquely to the left/right to turn. The chair can be rotated by moving the joystick (5) straight to the left/right.

To brake, release the joystick (5) so that it comes to rest in the neutral position (in the centre), or pull the joystick in the direction opposite to of the direction of travel for faster braking. Remember that the braking distance is affected by the slope of the surface underneath the chair.

Downhill = longer braking distance  
Uphill = shorter braking distance

To reverse, pull the joystick (5) backwards.

Horn: press button (8).

## OPERATION SEAT UNIT

To raise/lower the seat unit or the electric seat tilt/backrest angle or leg support angle. Press the option buttons (7). The electrical functions mounted on the chair become visible on the display (6) (one electrical function at a time is visible). Press the function buttons (7) to switch between the symbols or move the joystick sideways; selected symbols light up. Move the joystick forwards/backwards or right/left to operate the different selections.

Seat height adjustment: move the joystick (5) forwards to raise the seat height and backwards to lower it.

Seat tilt adjustment: move the joystick (5) forwards to tilt the seat forwards and backwards to tilt it backwards.

Backrest angle adjustment: move the joystick (5) forwards to tilt the backrest forwards and backwards to tilt it backwards.

## TO LOCK\*

### DX2-REM421 CONTROL UNIT

When the control unit is switched on, hold down the power button (1) for 4 seconds. A lock appears in the display (10). The control unit is turned off.

## TO UNLOCK\*

### DX2-REM421 CONTROL UNIT

Press the power button (1). A lock appears in the display. Press the horn (8) twice within the space of 10 seconds. The control unit is activated. When the chair's electrical function has not been used for five minutes it will automatically shut down to save battery power. Press any button to start up the electronics. The time interval for automatic shutdown is adjustable.



\* only works if the function has been activated in the program

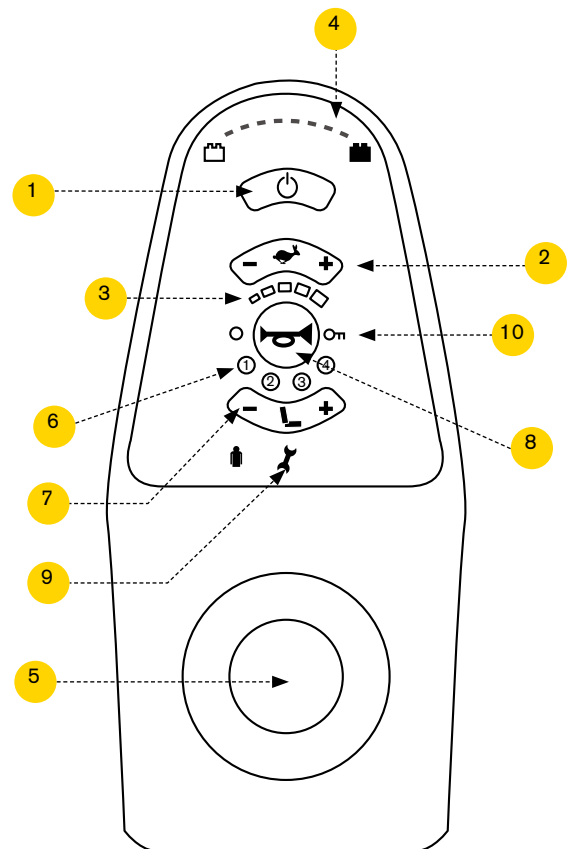

Control unit DX2-REM421

## OPERATION DRIVING

Turn on the main switch (1). Check the battery level (4). The battery level should not be down to the red marking. Make sure that the control unit does not generate a signal error (9), displayed at the upper edge of the display as a key with a number.

Runtime: Check that the display (3) is showing one of the driving programs. Press the driving program buttons (2) until one of these numbers appears. Set the running speed of the programs using the function buttons (6).

Move the joystick (5) straight ahead for forward movement and obliquely to the left/right to turn. The chair can be rotated by moving the joystick (5) straight to the left/right.

To brake, release the joystick (5) so that it comes to rest in the neutral position (in the centre), or pull the joystick in the direction opposite to of the direction of travel for faster braking. Remember that the braking distance is affected by the slope of the surface underneath the chair.

Downhill = longer braking distance  
Uphill = shorter braking distance

To reverse, pull the joystick (5) backwards.

Horn: press button (8).

## OPERATION SEAT UNIT

To raise/lower the seat unit or the electric seat tilt/backrest angle or leg support angle. Press the option buttons (7) until a chair is displayed.

The electrical functions mounted on the chair become visible on the display (one electrical function at a time is visible). Press the function buttons (6) to switch between the symbols or move the joystick sideways; selected symbols light up. The active electrical function will light up blue on the display (3). Move the joystick forwards/backwards or right/left to operate the different selections. The symbol on the display will change to green during adjustment. Seat height adjustment: move the joystick (5) forwards

to raise the seat height and backwards to lower it. Seat tilt adjustment: move the joystick (5) forwards to tilt the seat forwards and backwards to tilt it backwards. Backrest angle adjustment: move the joystick (5) forwards to tilt the backrest forwards and backwards to tilt it backwards.

## OPERATION ELECTRIC LEG SUPPORT - OPTIONAL

The height and the angle of the footplate can be adjusted. Press the option buttons (7) until a chair is displayed. Press the function buttons (6) or move the joystick (5) right/left to select the electric leg support function which is divided into right and left. Move the joystick (5) forwards to extend the electric leg support and angle it upwards and downwards to retract and move the electric leg support backwards. To only adjust the tilt on the left electric leg support, navigate to No. 1 and move the joystick (5) forwards to tilt the electric leg support upwards, and backwards to tilt it downwards. To extend/shorten the electric leg support only on the left side, navigate to No 2 and move the joystick (5) forwards to extend the leg support and backwards to retract it.

To adjust the angle of the electric leg support on the right side, navigate to No. 3 (see explanation for No. 1) and No 4 for vertical adjustment (see explanation for No. 2).

When the chair's electrical function has not been used for five minutes it will automatically shut down to save battery power. Press any button to start up the electronics. The time interval for automatic shutdown is adjustable.

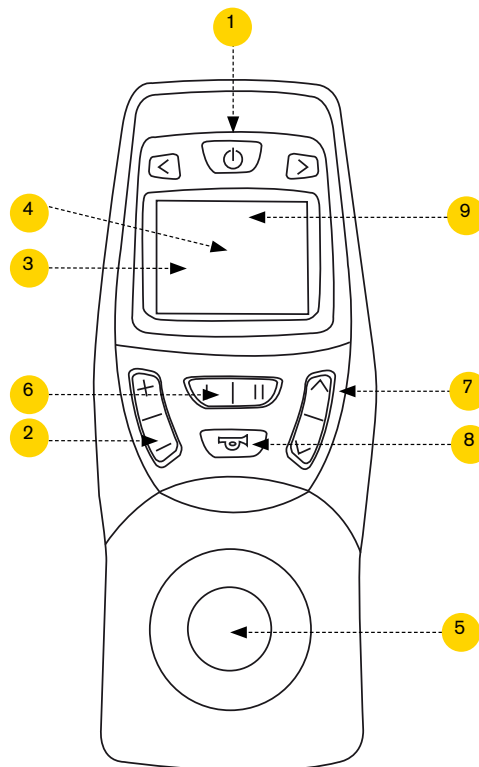

Control unit DX2-REM550

## TO LOCK\* CONTROL UNIT DX2

When the control unit is switched on, hold down the power button (1) for 4 seconds. A lock will appear in the display. The control unit is turned off.

## TO UNLOCK \* CONTROL UNIT DX2

Press the power button (1). A lock appears in the display. Press the horn (8) twice within the space of 10 seconds. The control unit is activated.



\* only works if the function has been activated in the program

# CHARGING

## DAILY USE

Connect the charger's charging plug to the charging jack on the control unit and the power cord to the wall socket. The charger indicates charging ongoing and charging completed.

! Remember to unplug the charging plug before using the chair.

Charge the chair for at least 12 hours prior to initial use. Deep discharges can damage the batteries, adversely, affect their capacity making it difficult to recharge the batteries properly. For this reason, the following recommendations should be followed:

- Charge the chair daily.
- Charge the chair as soon as possible if the control unit indicates a low battery.

If, despite everything, the batteries are discharged, the chair must be charged for at least 24 hours before being put back into service.

## LONG-TERM STORAGE

Disconnect the batteries if the chair is not going to be used for a long time. Do this by switching the automatic fuse to the "Off" position.

If the chair is going to be stored for more than four months, trickle-charge\* to ensure that the batteries retain their capacity. Please note that the automatic fuse must be switched to the "On" position in order to charge the chair.

Before putting the chair back into service, make sure that the automatic fuse has been switched to the "On" position and that the chair has been properly charged.





\* Since the charger uses very little power and will not overcharge the battery, it may be useful to leave it connected until the chair is put into service.

## WARNINGS

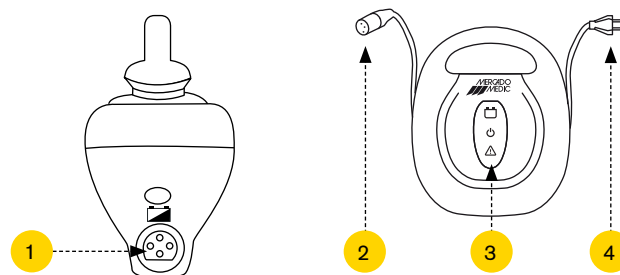
- ! Only charge the chair with the supplied EC Buddy ECB-401 4A 24V charger
- ! Batteries emit explosive gases when charging. Avoid flames and sparks.
- ! The charger is designed only for lead batteries with 12 cells (24V).
- ! The charger is equipped with protection against overheating but becomes warm during charging.
- ! Charging must be carried out in a well-ventilated area.
- ! The ambient temperature during charging must be between 10°C and 30°C
- ! Cables and connectors may only be replaced by the manufacturer or an authorised service centre.
- ! Cables and connectors should be checked for damage

1. Charging jack
2. Charging plug
3. Indicators
4. Power cord



INDICATION	SIGNIFICANCE/CAUSE	ACTION
 Steady light	Network connected	
 Flashing	Battery is being charged	
 Steady light	Battery is fully charged	
 Steady light	Incorrect battery polarity	Contact Service
 Flashing	Battery failure	Contact Service

or wear before each charge. Replace the charger immediately if a defect is detected.

- ! Excessive heat build-up on any connector may be a sign of wear or damage. In such cases, both the female and male connectors or the entire charger should be replaced.
- ! Never short-circuit the battery.
- ! Do not subject the battery to strong physical force.
- ! The battery should be replaced after three (3) years to reduce the risk of leakage.
- ! In the event of contact with battery acid, rinse with water for approx. 15 mins and seek medical advice.
- ! Discarded batteries must always be handed in at recycling centres.

## CONTINUED CHARGING

### IMPORTANT INFORMATION

- The charger is equipped with protection against incorrect polarity, the short-circuiting of battery cables, mains/battery sparking, and overheating
- The charger should not be exposed to direct sunlight.
- The charger must not, fully or partially, be immersed in water or covered with snow.
- Cleaning the charger is performed as needed with a lightly dampened cloth.
- The charger complies with the following standards: EN 60601-1, EN 60601-1-2, EN 12184, ISO 7176-14. The combination of chair and charger also complies with ISO 7176-21.
- Keep chargers, connectors and batteries free of dirt, dust and oxide.

## SERVICE AND TROUBLESHOOTING OF CONTROL UNIT DX/DX2

### ERROR MESSAGE IN CASE OF OUTAGES

Each fault on DX will be indicated by flashing signals on the control unit's check light at the on/off switch. The flashes come in groups of 1-12 with an interval of 2 seconds. The number (1-12) of flashes indicate the fault that has occurred.

### ABOUT THE TABLE

The electric wheelchair will stop automatically in the event of any serious faults that affect driving safety. Less serious faults will only be indicated by the indicator light and it will be possible to continue driving the electric wheelchair.

For some faults, the electronics will be reset once the fault has been corrected, and the check light will once again show a steady light. Other faults may be connected, which means that the electric wheelchair must be turned off for at least 2 seconds and then switched on again to reset the fault.

For less serious faults, the electronics may switch to the backup driving mode. This means that it will still be possible to drive the electric wheelchair, but all speed variables will be lowered.

NUMBER OF FLASHES	TYPE OF FAULT
1	DX module
2	DX accessories
3	Left motor (M1)
4	Right motor (M2)
5	Left parking brake (M1)
6	Right parking brake (M2)
7	Low battery voltage
8	High battery voltage
9	Bus cable
10	Bus cable
11	Overload
12	Compatibility errors

### 1 FLASH - DX MODULE ERROR

This means that one of the DX modules is faulty and needs to be replaced. Inspect the check lights on the modules. If any of these flash, it means that the module is broken (the status of the control unit is indicated via the number window).

### 2 FLASHES – DX ACCESSORIES

The signal could mean two things. If the chair is equipped with an electric lift device, the signal indicates that the seat is in the lifted position and the chair's speed reduction is activated. The signal may also indicate that an electric device is broken or has a contact error. Check all electrical functions and contacts and wiring.

### 3 FLASHES – LEFT (M1) MOTOR

This means that there is a break or short-circuit on the lead from the electronic module's M1 connector to the motor, or fault with the motor. Check by unplugging the M1 connection and measuring the resistance between the two outer pins (1 and 4) in order to detect any break or short-circuit.

### 4 FLASHES – RIGHT (M2) MOTOR

See 3 *FLASHES*, but for the M2 connector.

### 5 FLASHES – LEFT (M1) PARKING BRAKE

This means that there is a break or short-circuit on the electronic module's M1 connector to the parking brake, or a fault on the parking brake. Check by unplugging the M1 connection and measuring the resistance between the two inner pins (2 and 3) in order to detect any break or short-circuit. Also check that the parking brake disengage control properly resets the brakes when the lever is moved into driving mode.

### 6 FLASHES – RIGHT (M2) PARKING BRAKE

See above, but for the M2 connector.

### 7 FLASHES – BATTERY VOLTAGE TOO LOW

This signifies that battery voltage is too low to be able to operate the electric wheelchair. Charge the battery and check that the charger's check light indicates that the chair is charging. If the fault persists, measure the battery voltage both during charging and without the charger connected. If there is a significant difference in voltage, the batteries are probably in poor condition and need to be replaced. Also check the batteries' connections and wiring.

### 8 FLASHES – LOW BATTERY VOLTAGE

This signifies that battery voltage exceeds 32 V. Normally, this can only occur while charging and indicates that the charger is faulty.

### 9 FLASHES – CANL – ERROR

This means that there is a disturbance (breakage or short circuit) in the cabling. The control system continues to operate in standby driving mode. The chair will still be operational, but with limited speed. The error should be identified and corrected as soon as possible. One possible cause of the fault is a damaged BUS cable between the control unit and the electronics unit. Check BUS cables for damage to cable or plug pins.

### 10 FLASHES – CANH – ERROR

The CANH line BUS cable is used for communication between electronic modules. A signal can be generated manually, e.g. via an emergency switch or automatically from any module that detects a fault and shuts down the system. This means that CANH errors can be caused by many types of problems. If possible, the control system will continue to operate in standby driving mode. The chair will still be operational, but with limited speed. Check BUS cables for damage to cable or plug pins.

### 11 FLASHES – OVERLOAD

Power to the motors has continuously exceeded the limit value. Turn off the system and allow all components to cool down. Disengage the chair and check that the drive wheels can rotate freely. Make sure none of the motors are hot. To reset the chair, restart the electrical system.

### 12 FLASHES – COMPATIBILITY ERROR

This means that there is a compatibility error between two or more electronic modules in the DX system or that one module has been programmed incorrectly. This error cannot occur on a chair that is in operation. Make sure the correct program is downloaded.



## SERVICE AND TROUBLESHOOTING OF REAL 6100 PLUS

SYMPTOM	CAUSE	ACTION
Control unit does not work	Control unit broken	Reprogram or replace it
Control unit does not work	Cabling broken	Replace
Control unit does not work	Battery	Replace
Wheels are not moving Drive motor is quiet	The freewheel mechanism is disengaged or out of operation	Check whether the freewheel mechanism is locked Replace it
Wheels are not moving	Drive motor broken	Replace
The seat allows a large degree of play in the direction of rotation	Noise due to actuator play	Renovation
The electrical lifting mechanism does not work	Safety clutch	Set skid brake or contact service
Noise in castors	Unlubricated or worn bearings	Lubrication or replacement
Worn drive wheels	Old/spent wheels	Replace

## PROGRAMMING SCHEDULE

DEFAULT PROGRAM			
	<b>DX2</b>		
	PROG. 1	PROG. 2	PROG. 3
Maximum forward speed	25%	45%	75%
Forward acceleration	20%	25%	30%
Forward deceleration	35%	40%	50%
Maximum reverse speed	20%	25%	50%
Reverse acceleration	20%	20%	25%
Reverse deceleration	35%	35%	50%
Maximum turning speed	15%	20%	45%
Turning acceleration	20%	20%	25%
Turning deceleration	35%	40%	55%

## ! Important information:

- The Product does not require periodic maintenance in cases where it has a responsible prescriber in the healthcare sector. In markets outside of Sweden and Norway where a distributor has sold the Product directly to the user (where applicable), and therefore there is no responsible prescriber, periodic maintenance must be carried out every other year during the Product's entire life cycle according to sections 1-12 in this section.
- A thorough visual inspection must be performed of the Product's main components in connection with service and reconditioning in order to ensure the user's safety. This includes the chassis, lifting mechanism, seat frame, back recliner and U-bars for armrests. The check must include welds, lockable functions, cabling and settings.
- If faults or damage are discovered, avoid using the chair until it has been inspected and approved by qualified service personnel.
- The user must not sit in the chair while it is being reconditioned or serviced or during maintenance.
- For safety reasons, before a used chair is prescribed to a new user, the seat frame and the back recliner should be replaced.
- Do not use high pressure washers when cleaning the chair.

### 1. Electronics unit

- 1.1. Electronics / function / cleaning

Connect the Wizard program and read off the diagnostics. Check active errors and diagnostics. Fix any errors and reset the log.

- 1.2. Control unit/function/cleaning

Check the functions of the control unit, and check that the joystick bellows is intact and that all buttons are working. Wipe the control unit with a cloth lightly dampened with disinfectant; this is to avoid the risk of spreading infection. Do not use solvents, bleach, polishes, synthetic detergents, polishing waxes or sprays on the chair.

- 1.3. Electrical seat functions (DCI)/ function

Check that plugged in electrical functions are working and that the 12-pin connector on the power module is not loose or has any visible damage.

- 1.4. Connectors, attachment

Check that cables and connectors are intact and properly secured. Make sure that cables and connectors cannot be pinched or crushed.

- 1.5. Batteries/battery charger/ function

Check that the charger is working and that the housing and cables are undamaged. Measure the battery voltage and check that the difference in battery charge level is not too great; this indicates that a battery cell has failed.

- 1.6. Electric seat tilt/function

Check that the actuator is not visibly damaged. Check the function of the actuator's moving parts. Ensure that all locking screws are tightened to avoid any play in the end position.

- 1.7. Electric backrest/function

Check that the actuator is not visibly damaged. Check the function of the actuator's moving parts. Ensure that all locking screws are tightened to avoid

any play in the end position.

- 1.8. Electric leg support/function  
Check that the actuator is not visibly damaged. Check the function of the actuator's moving parts. Ensure that all locking screws are tightened to avoid any play in the end position. Check all joints and that the lower clamping bracket is securely tightened

### 2. Electric lifting mechanism

- 2.1. Noise / sliding clutch

Listen for any abnormal noise in the gearbox bearings, and replace the electric lifting mechanism if a bearing is defective in any way. The electric lifting mechanism can be sent to Mercado Medic AB for repair/reconditioning. Load the chair and check that the electric lifting mechanism does not slip in its bottom position. If the electric lifting mechanism slips, tighten the safety clutch until the electric lifting mechanism no longer slips.

- 2.2. Rotation lock / lubrication

Check that there is no play in the electric lifting mechanism in the direction of rotation. If there is, replace the electric lifting mechanism. The electric lifting mechanism can be sent to Mercado Medic AB for repair/reconditioning.

- 3.3. Attachment/tightening

Check that the attachments to the seat frame and base are securely tightened.

- 4.4. Cabling/wear

Inspect cables for any signs of wear, pinching or crushing.

### 3. Chassis

- 3.1. Welds

Check all welds carefully for signs of cracks, corrosion, movement, etc.

- 3.2. Bolted joints

Check and tighten all bolted joints. Replace screws that have damaged heads or threads.

### 4. Drive wheels

- 4.1. Function/wear

Check that the drive wheels have good tyre treads and that they have not dried out (will result in poor friction to the floor).

- 4.2. Bearings/wheel tracks

Check that the drive wheels are rolling properly and that there is no play in the motors' gears.

- 4.3. Attachments/tightening

Remove the drive wheels and check the motor screw joints. If necessary, blow off all dust and dirt from the motors.

### 5. Castors

- 5.1. Function / roll / swivel

Remove hair and dust from the castors and check castors and castor housings for wear and play, which may indicate defective bearings. Check that the castors swivel and the housings rotate as expected. Replace castors if necessary.

- 5.2. Attachment/tightening

Check that the castor screws are intact and tightened.

### 6. Brake release

- 6.1. Function

Check that there is no play in the brake release control and that the magnet activates the sensor upon disconnection. Make sure that the drive wheels rotate easily when disengaged.

- 6.2. Setting/tightening

If the brake release does not properly reconnect, adjust the brake release mechanism.

### 7. Seat frame

- 7.1. Mechanics/welds

Thoroughly inspect all welded parts (especially when installing tilt mechanisms, as these parts carry the most load).

# CHECKLIST RECONDITIONING AND SERVICE REAL 6100 PLUS, CONT.

## 7.2. Screw joints/tightening

Check and tighten all screw joints. Replace screws that have damaged key handles or threads.

## 7.3. Plastic plugs / guide bushings

Make sure that guide bushings and plastic plugs are properly secured, and replace worn or damaged parts.

## 7.4. Seat/replacement/cleaning

Replace the seat with a new one and wash or replace any covers

## 7.5. Operation/lubrication

Make sure that all knobs and levers on the seat frame are working and that they lock correctly.

## 7.6. Gas spring tilt/function

If the chair is equipped with a gas spring tilt, check that this locks securely and that there is no gradual change in tilt when loaded. Check and replace damaged wires and sheaths.

## 7.7. Crank tilt/wear

If the chair is equipped with crank tilt controls, check that there is no play and that all screws are tightened.

## 7.8. Coxit mechanism/operation

Make sure that the knobs for the flaps turn easily and are securely locked with the counter nut.

## **8. Backrest mechanism**

### 8.1. Function/wear

Check and replace any worn parts, and make sure that moving parts are working correctly.

## 8.2. Attachment/tightening

Check that all screws, knobs and levers lock properly and that the button clips are working correctly.

## 8.3. Plastic plugs/guide bushings

Make sure that guide bushings and plastic plugs are properly secured, and replace worn or damaged parts.

## 8.4. Backrest/replacement/cleaning

Replace the backrest with a new one and wash or replace any covers

## 8.5. Gas spring lever/function

Check the gas pressure and stability of the gas spring. Ensure that it locks securely and that there is no gradual change in the backrest angle when loaded. Check and replace damaged wires and sheaths.

## **9. Armrests**

### 9.1. Function/wear

Check and replace any worn parts and make sure that locking mechanisms and moving parts are working correctly.

### 9.2. Plastic plugs/guide bushings

Make sure that guide bushings and plastic plugs are properly secured, and replace worn or damaged parts.

### 9.3. Armrest plates/replacement/cleaning

Replace armrest plates with new ones.

### 9.4. Armrest mechanics/function

Check all welds and that there is no damage to the tube system that may impair or weaken the structure.

## **10. Accessories**

### 10.1. Reset

Remove any accessories that are not normally installed on the chair and inspect them as detailed below before potentially placing them in storage.

### 10.2. Mechanics

Inspect all welds and that there is no damage to mechanical parts that may impair or weaken the structure.

### 10.3. Function/wear

Check and replace any worn parts and make sure that locking mechanisms and moving parts are working correctly.

### 10.4. Padded parts

Discard padded parts so that they do not pass on any infection. Discard or wash covers according to washing instructions.

## **11. Programming**

- Restore the application to its default application. Make sure that all logs are reset if the chair is going to be turned over to another user.

## **12. Test drive**

- Test drive the chair and ensure that all electric functions, driving programs and brakes work in accordance with the standard program. If the chair is to be placed in storage, the main fuse on the front side of the battery box should be disconnected to save battery consumption.

# INSTRUCTIONS FOR DESTRUCTION

Instructions for source separation of components. The highest possible component weight in kg (depends on chair configuration) is specified for each component.

### Combustible:

- Seat (3.2 kg)
- Backrest (4 kg)
- Neck support (0.7 kg)
- Armrest (0.7 kg)
- Other padded parts sold by Mercado Medic AB

### Plastics:

- Covers are sorted for disposal in accordance with markings on the plastic. If there is no marking, sort these as combustible.

### Metal:

- Armrest mechanism (1.8 kg)
- Backrest mechanism (7.2 kg)
- Neck support mechanism (2.6 kg)
- Leg support (3.3 kg)
- Base (22.5 kg)
- Seat frame (7.7 kg)
- Actuator, tilt etc. (1.3 kg)
- Actuator up/down (3.6 kg)

- Gas spring for seat tilt (0.3 kg)
- Gas piston (3.2 kg)
- Other metal parts in products sold by Mercado Medic AB

### Electronic waste:

- Motors (3.2 kg)
- Cables (0.3 kg)
- Power module (0.9 kg)
- Joystick (0.4 kg)
- Actuator box (0.15 kg)

### Lead battery:

- Batteries (9.7 kg/unit)

## GUIDELINES FOR INDIVIDUAL CUSTOMISATIONS OF MERCADO MEDIC AB PRODUCTS

Customisations may only be carried out by authorised personnel who have completed Mercado Medic AB's training programme for service and reconditioning. Parts that are on the list of current combination agreements at [www.mercado.se/mercado-dokument](http://www.mercado.se/mercado-dokument) can be fitted while retaining Mercado Medic AB's CE marking. If a desired item that is not on the list of current combination agreements is fitted, the customer's authorised personnel must contact Mercado Medic AB for written approval.

Parts to be evaluated must be sent physically to Mercado Medic AB, either by the customer or the supplier of the part in question. Mercado Medic AB will then contact the supplier of the part in question. If a combination agreement is of interest, Mercado Medic AB will conduct a risk analysis on the desired part. Once the risk analysis has been completed, the customer will receive a written statement.

Chairs that have been modified according to the following must be verified by Mercado Medic AB in order for Mercado Medic AB to retain product liability.

- Padded parts (such as seats, backrests, armrests, side supports, trunk supports and neck supports) have been adapted outside of the product's existing external dimensions.
- The centre of gravity over lifting devices (must be retained/centred for optimum function) has been changed.
- Padded parts that do not meet applicable ignitability requirements and/or other environmental requirements have been used.
- Surfaces that are loaded with significant vertical forces must not fall outside the area (base) that is formed by the contact points of the castors against the floor.

If these guidelines are met, Mercado Medic AB retains the product liability for its product.

Products that are customised by health care services outside Mercado Medic AB's directive, where health care services also take over product liability, can be restored to their original condition. This must be carried out by an authorised technician approved by Mercado Medic AB. Mercado Medic AB will then re-assume product liability in accordance with the CE marking 93/42 EEC; Medical Devices Directive MDD.

If you have any questions regarding customisations/special adaptations, please contact Mercado Medic AB's Product Manager, Ronny Fogelqvist:  
Tel. [+46 \(0\)708 27 96 14](tel:+460708279614)  
E-mail [ronny.fogelqvist@mercado.se](mailto:ronny.fogelqvist@mercado.se)

*[Space for product label with serial number.]*



**Mercado Medic AB**  
Tryffelslingan 14  
SE-181 57 Lidingö

**Telephone & Fax**  
Tel +46 (0)8-555 143 00  
Fax +46 (0)8-555 143 99

**E-mail & Internet**  
E-mail [info@mercado.se](mailto:info@mercado.se)  
Internet [www.mercado.se](http://www.mercado.se)