



REAL® 9000 PLUS SERIES



INSTRUCTIONS FOR ASSEMBLY, USE & CARE

REAL 9000 PLUS/EL/ADULT/CHILD/MINI/COXIT

Doc. no: 20-06352-UK-03
Art. no: 804838
Amended 2020-12-04
Valid from 2017-06-01

REAL 9000 PLUS is a Class I medical device. It is CE marked in accordance with the Swedish Medical Products Agency's code of statutes for medical devices, LVFS 2003:11, and has been tested and approved in accordance with EN 1335, IEC 60601 and EN 12182. All textiles used in the chair have been tested and approved in accordance with EN 1021-1 and EN 1021-2. Mercado Medic AB is certified to ISO 9001, ISO 14001 and ISO 13485 and complies with applicable labour and environmental legislation.

If you have any questions about your product or if something unexpected has happened, please contact your dealer first, otherwise you are welcome to contact us at Mercado Medic AB.

PDF versions of our instructions for use and care with magnification options can be found on our website: www.mercado.se. Information is also provided on the website about accessories that can be installed on Mercado Medic's chairs, as well as any field safety notices, prescribing support or recalls of products and accessories.

We reserve the right to make changes to this manual and its contents.

YOUR REAL® 9000 PLUS

- Adult
- Child/Mini
- Coxit
- Manual
- El 24V

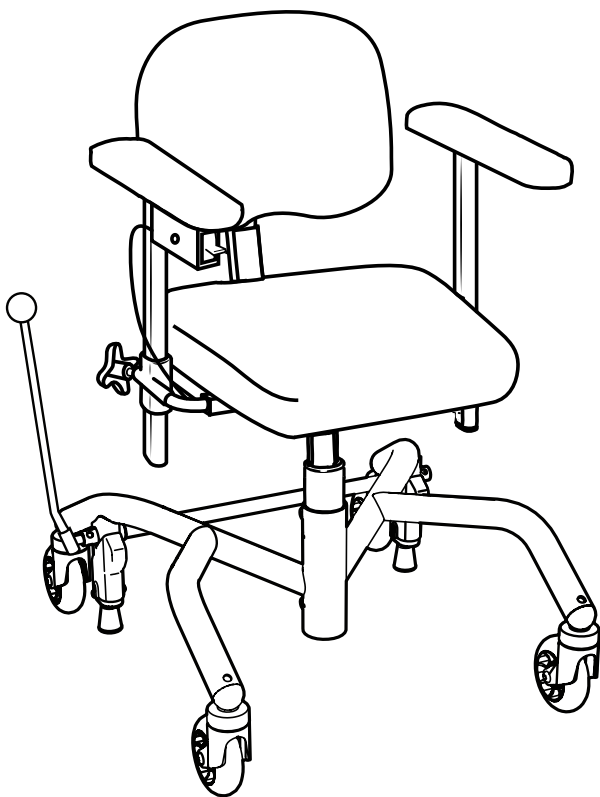

TABLE OF CONTENTS

- Assembly for use 2
- Familiarise yourself with REAL 9000 PLUS 3
- Important information & class 3
- Expected service life 4
- Cleaning & care 4
- Instructions for destruction 4
- Symbols 5
- Reconditioning and service 5
- Individual adaptation 7
- User manual 8
 - Brake 8
 - Seat height/lifting mechanisms 8
 - Seat tilt (option) 8
 - Reversed seat tilt or full seat tilt backwards (Option) 9
 - Backrest mechanism 9
 - Armrests 9
 - Setting the coxit flaps 10
 - Rotation release (Option) 10
 - Charging 10
 - Charging, Cont. 11

Sufficient competence in the safe use of this product is achieved by carefully reading through these instructions for use and care before using the chair for the first time.

Brake lever

Remove the chair from the cardboard box. Place the brake lever in the brake lever bracket (1) on the right or left side.

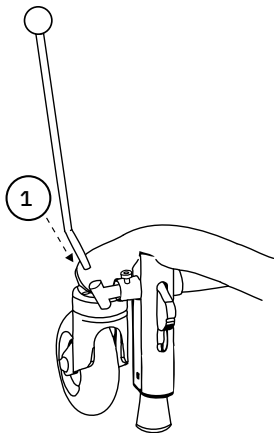

Armrests

Loosen the controls for the armrest (2). Set the desired level in height and width. Tighten all controls (2).

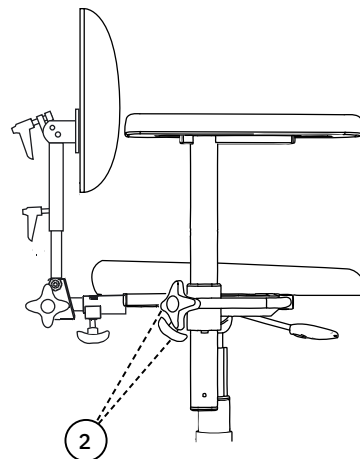

Backrest mechanism

Assemble the backrest mechanism by pushing the backrest support post on the backrest mechanism (3) down to the desired level. Then tighten all of the knobs and levers (4).

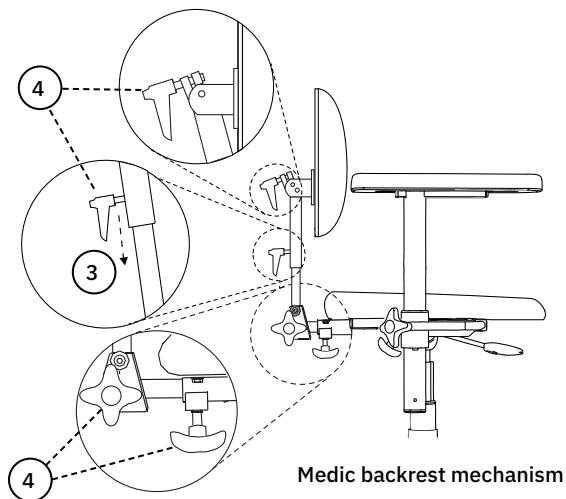
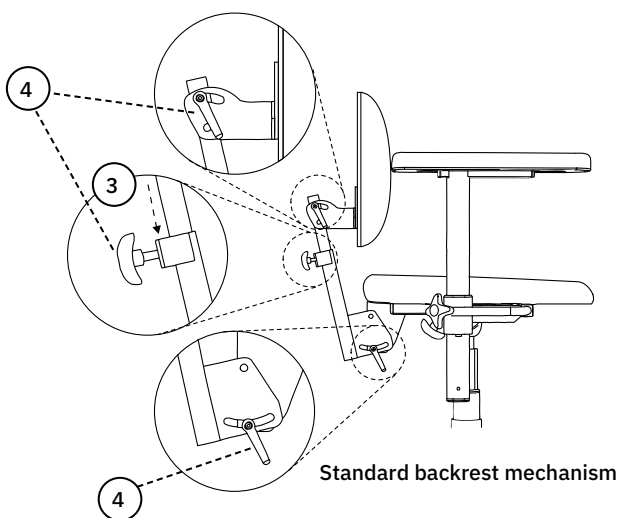

Neck support

If the chair comes with a neck support, place the neck support mechanism in its bracket on the backrest as illustrated. Then tighten all of the knobs and levers (5).

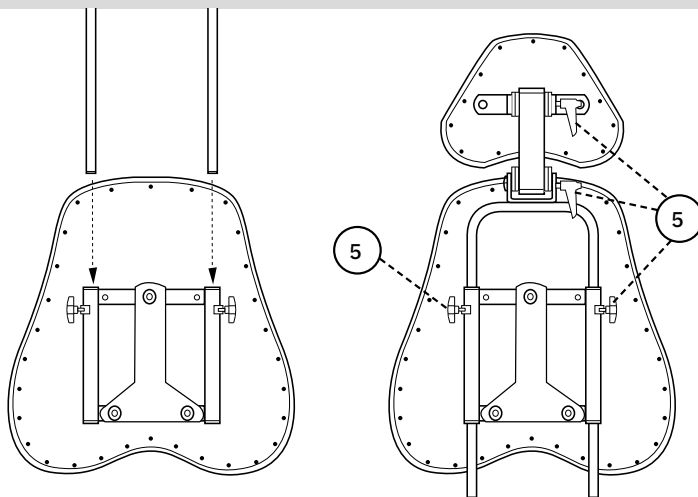

The chair is now ready for use! >>

Necessary information before use

1. Adjust the armrests to a suitable height and lock the knob for height adjustment.
2. Fit the backrest support post in the intended bracket and lock the knob for height adjustment of the backrest.
3. Fit the brake lever in the intended bracket (left or right side). Does not apply to electric brakes.
4. All knobs and levers must be tightened before sitting in the chair.
5. The brake on the chair must always be applied when getting in and out of the chair. The brake must be checked on a regular basis.
6. Applies to electric chairs: Charge the chair according to the instructions in this manual, see page 11.
NOTE! The chair should be charged daily.
7. The chair must not be used with the backrest and/or armrests removed.

IMPORTANT INFORMATION & CLASS

The REAL chair has interchangeable components, accessories and functions with setting options for individual adaptation. The chair must only be used by the person for whom it was prescribed and for the purpose for which it is intended. The chair is intended for indoor use only and must not be used outdoors. The chair must not be exposed to extreme cold or heat, prolonged sunlight or other radiation. The chair must not be exposed to water, other fluids or chemicals. Warning! Metal surfaces may become very hot if they are exposed to direct sunlight. The chair must not be equipped with any accessories or components other than those approved by Mercado Medic AB. To maintain the CE marking, modifications or changes must not be carried out without Mercado Medic AB's approval. Repairs and other technical measures may only be carried out by personnel authorised by Mercado Medic AB. Read this manual carefully before using the chair for the first time.

- REAL PLUS EL complies with protection class II, internal battery.
- REAL PLUS EL complies with protection type B.
- REAL PLUS EL has been EMC tested and tested in accordance with EN 60601-1-1 and EN 60601-1-2, and must therefore be handled in accordance with our instructions for use and care.
- REAL PLUS EL complies with IP 21. IP2X covers contact protection for fingers etc., preventing access to hazardous parts with fingers or similar. IPx1 covers vertical drip protection, light shower from above.
- Max. user weight, adult: REAL PLUS MANUAL 140 kg. REAL PLUS EL 150 kg.
- Max. user weight, child: REAL PLUS MANUAL 75 kg. REAL PLUS EL 75 kg.
- REAL 9000 PLUS is approved to stand with the brake applied on inclines up to five degrees in all directions. If the chair is standing with the brake applied on steeper inclines, it may begin to slide.
- NOTE! The electrical functions on REAL PLUS EL chairs may be used for max. 10 % of the time (max. 2 mins/20 mins). The electronics measure activity, except that for raising and lowering, and shut down the electrical functions if this time limit is exceeded.
- Only tested and approved batteries and chargers from Mercado Medic AB may be used with REAL PLUS EL.
- Warning! Do not plug any accessory, other than those customised by Mercado Medic AB, into the control system's contacts.
- Mercado Medic's armrests, seats, backrests, etc. have been developed and produced to be free from toxic substances and allergens.
- The chair is tested and approved for use between +5°C and +40°C and 15 to 90 % non-condensing humidity. If the chair has been stored in an environment outside these limits, it must be left to acclimatise before use in order to ensure that it can be used safely.
- REAL PLUS EL has an electric lifting mechanism that can lift the patient so high that, in the worst case, a risk is introduced. If the patient cannot get out of the chair from its highest position, then the seat height should never be higher than the position at which the patient's feet touch the ground. The only exception to this is cases where the patient can summon help via a home-help alarm or telephone.
- If REAL PLUS EL is equipped with leg support, the user's feet must remain on the footplate when using the electrical functions.
- The chair must be operated with care. Before moving off, consideration must be given to the surroundings. Any pets or children on the floor could be easily run into. The chair must only be used to sit on and should not be regarded as a toy by either children or adults.
- REAL PLUS EL is approved for transportation/storage at temperatures between -25°C and +60°C and up to 90 % non-condensing relative humidity.
- The chair must be transported in the intended cardboard box on a pallet. If the chair is transported by car, it must be strapped in place using straps over both the base and the seat, and it should be set to the lowest possible seat height.
- Repairs and other technical measures may only be carried out by personnel authorised by Mercado Medic AB.
- The chair must not be used at altitudes greater than 2,000 m above sea level.
- REAL Plus is always delivered as standard with seat, backrest and armrests, and a handheld controller for chairs with electrical functions.
- REAL PLUS chairs must not be moved when the seat is in the raised position.
- The warranty period is two (2) years unless otherwise agreed. For warranty cases, please contact Mercado Medic AB.
- The expected service life is ten (10) years.
- REAL PLUS can be complemented with a variety of accessories. All accessories must be installed so that there is no risk of small parts (such as fuses, etc.) coming loose. All cables must be secured with cable ties to the chair's frame to minimise the risk of strangulation.

EXPECTED SERVICE LIFE

The expected service life of the Product is ten years when used in accordance with the instructions in this manual. The Product's date of manufacture can be found together with the serial number on one of the silver labels on the Product's chassis, marked with Lev/Del and stated in the format YYWW (number of year and week).

As a user of the Product, you should contact your prescriber, technical aids centre or distributor if the Product shows reduced or altered performance.

After the expected service life, it is important to make an overall assessment of the Product before continuing to use it. After the expected service life, Mercado Medic AB cannot guarantee the suitability and safety of the product, as Mercado Medic AB has no control over how the product has been used and wear and tear. The overall assessment of the Product should be carried out by the healthcare organisation if the product is prescribed, and, as a minimum, should take into account how the Product has been used, the condition of the Product and its component parts, whether the Product has been reconditioned and been serviced, when this occurred, what actions have been taken on these occasions and the reason for the actions.

In markets outside Sweden and Norway where a distributor has sold the Product directly to the user (where applicable), and therefore there is no responsible prescriber, periodic maintenance must be carried out according to instructions in the section Reconditioning and Service in addition to the overall assessment above.

After the expected service life, Mercado Medic AB cannot guarantee the provision of spare parts. CE marking is not affected by expected service life.

CLEANING AND CARE

- The chair should be wiped down and kept free from dust and dirt.
- The chair should be washed using a disinfectant with a pH of 7-12 (concentrated), with the exception of the padding.
- Plush upholstery has to be washed with a foam wash:
 1. Remove loose dirt, crumbs and the like.
 2. Apply a thin layer of foam and rub the foam in evenly with a damp cloth.
 3. Wipe with a clean and lightly dampened cloth.
 4. Vacuum clean when dry.
- Artificial leather has to be washed with soapy water or alternatively wiped down with an alcohol solution, e.g. disinfectant.
- Leather upholstery requires a little extra maintenance:
 - Spills must be wiped up immediately with a damp cloth, never use strong cleaning agents.
 - Prevent upholstery from coming into contact with personal care products, such as make-up, hair gel, etc.
 - Do not allow pets on leather furniture, as their claws may scratch the leather.
 - Avoid direct and prolonged exposure to sunlight, as this can cause the leather to fade over time.
- For functional reasons, seats, backrests and other padded parts are not made from impermeable materials. Padded parts should be replaced during reconditioning for hygienic reasons.
- The electric lifting mechanism should be checked regularly for dust, dirt and stability: Raise the seat to its highest position. Clean with a cloth. Do not use any water or solvents. Then lubricate the cylinder using a thin layer of Teflon or silicone-based grease.
- The user or their assistant should remove dust, wipe clean and dry off the padded parts on the chair in accordance with the instructions above to the best of their ability and as needed. If this is not done satisfactorily, the chair will need to be reconditioned in order to guarantee hygienic safety.

INSTRUCTIONS FOR DESTRUCTION

Combustible:

- Seat
- Backrest
- Armrest
- Neck support
- Other padded parts sold by Mercado Medic AB

Electronic waste:

- Motors
- Cables
- Control system

Metal:

- Base
- Electric lifting mechanism
- Gas pistons
- Gas springs
- Seat frame
- Backrest mechanism
- U-bars and armrest mechanism
- Other metal parts in products sold by Mercado Medic AB

PLEASE NOTE! Battery has to be sorted separately.

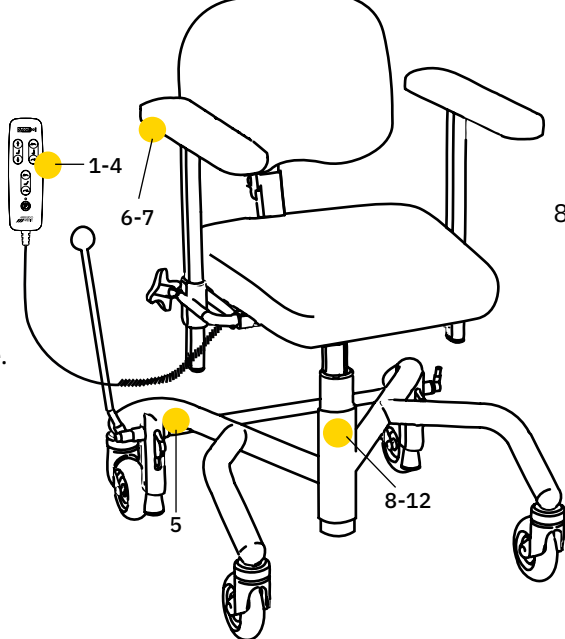



 1. Seat height up/down.

 2. Seat tilt forwards/backwards.

 3. Back recliner forwards/backwards.

 4. Activate/release brake.

 5. Risk of crushing. Potential risks indicated.

6. Warning! Read the manual before use. 

7. Charging connection.  24VDC

8. Separation of source materials 

9. The product is part of a recycling process. 

10. Product classified as type B applied part in accordance with IEC 60601-1. 

11. Max. user weight 

12. Time in use for electrical functions  INTERMITTENS 2/20 MIN DUTY CYCLE

RECONDITIONING AND SERVICE

! Important information for reconditioning and servicing REAL 9000 PLUS chairs (hereinafter referred to as the Product):

- The Product does not require periodic maintenance in cases where it has a responsible prescriber in the healthcare sector. In markets outside Sweden and Norway where a distributor has sold the Product directly to the user (where applicable), and therefore there is no responsible prescriber, periodic maintenance must be carried out every other year throughout the Product's entire life cycle according to sections 1-10 in this section.
- A thorough visual inspection must be performed of the Product's main components in connection with service and reconditioning in order to ensure the user's safety. These include the base, lifting mechanism, seat frame, back recliner and U-bars for armrests. The inspection must include welds, lockable functions and settings.
- The user must not sit in the Product while it is being reconditioned or serviced or during maintenance.
- Do not use high pressure washers when cleaning the Product.
- When checking the base, always inspect the weld between the base's front and rear legs. Any indication of cracks in the material or paint in this area should be regarded as reason to replace the base, or the Product.
- In case of reduced braking action, check both the stability of the base and the condition of the brake rubber. If the Product is not resting on all four wheels in the unbraked position, the Product must be withdrawn from service immediately. Check for instability in different locations and directions to rule out the floor as the cause of any instability.

1. Electronics unit

1.1. Electronics/function/cleaning
Check the electronics and see which electrical functions are connected. Test electrical functions; if the chair does not work, try connecting the charger for at least 10 seconds. Check for any damage to the electronics box.

1.2. Control unit / function / cleaning

Check the functions of the controls, and check that the housing is intact and that all buttons are working. Wipe the controls with a cloth lightly dampened with disinfectant; this is to avoid the risk

of cross-infection. Do not use solvents, bleach, polishes, synthetic detergents, polishing waxes or sprays on the chair.

1.3. Connectors / attachment
Check that cables and connectors are intact and properly secured. Make sure that cables and connectors cannot be pinched or crushed.

1.4. Batteries/battery charger/ function

Check that the charger is working and that the housing and cables are undamaged.

Check the batteries' voltage and that there is not too great a difference

between the batteries' charge; this indicates that a battery cell has failed.

1.5. Electric seat tilt / function
Check that the actuator is not visibly damaged. Check the function of the actuator's moving parts. Ensure that all locking screws are tightened to avoid any play in the end position.

1.6. Electric backrest / function
Check that the actuator is not visibly damaged. Check the function of the actuator's moving parts. Ensure that all locking screws are tightened to avoid any play in the end position.

- 1.7. Electric brake / function
Check that the actuator is not visibly damaged. Check the function of the actuator's moving parts. Ensure that all locking screws are tightened to avoid any play in the end position.

Check all joints and that the clamp mounting on the brake shaft and base tube is correctly positioned.

2. Electric lifting mechanism

- 2.1. Noise / sliding clutch
Listen for any abnormal noise in the electric lifting mechanism, and replace the electric lifting mechanism if a bearing is defective in any way. The electric lifting mechanism can be sent to Mercado Medic AB for repair/reconditioning.

Load the chair and check that the electric lifting mechanism does not slip to lowered. Otherwise ensure the correct torque for the sliding clutch.

- 2.2. Rotation lock / lubrication
Check that there is no play in the electric lifting mechanism in the direction of rotation. If there is, replace the electric lifting mechanism. The electric lifting mechanism can be sent to Mercado Medic AB for repair/reconditioning.

- 2.3. Attachment / tightening
Check that the seat frame and base are correctly assembled and tightened.

- 2.4. Cabling / wear
Inspect cables for any signs of wear, pinching or crushing.

3. Chassis

- 3.1. Welds
Check all welds carefully for signs of cracks, corrosion, movement, etc.

- 3.2. Bolted joints
Check and tighten all bolted joints. Replace screws that have damaged heads or threads.

4. Brakes

- 4.1. Function / wear
Replace the brake rubber and check that the brake is working properly.
- 4.2. Plastic plugs / guide bushings
Make sure that guide bushings and plastic plugs are properly secured, and replace worn or damaged parts.

5. Castors

- 5.1. Function / roll / swivel
Remove hair and dust from the castors and check castors and castor housings for wear and play, which may indicate defective bearings. Check that the castors swivel and the housings rotate as expected. Replace castors if necessary.

- 5.2. Attachment / tightening
Check that the castors' screws are intact and tightened.

6. Seat frame

- 6.1. Mechanics / welds
Check all welded parts carefully (especially when mounting tilt mechanisms, as these parts carry the most load).
- 6.2. Bolted joints / tightening
Check and tighten all bolted joints. Replace screws that have damaged heads or threads.
- 6.3. Plastic plugs / guide bushings
Make sure that guide bushings and plastic plugs are properly secured, and replace worn or damaged parts.
- 6.4. Seat / replacement / cleaning
Replace the seat with a new one and wash or replace any covers.
- 6.5. Control / lubrication
Make sure that all knobs and wheels on the seat frame are working and that they lock correctly.
- 6.6. Gas spring tilt / function
If the chair is equipped with gas tilt controls, check that these lock securely and that there is no gradual change in tilt when loaded. Check and replace damaged wires and sheaths.
- 6.7. Crank tilt controls / wear
If the chair is equipped with crank tilt controls, check that there is no play and that all screws are tightened.
- 6.8. Coxit mechanism / control
Make sure that the knobs for the flaps turn easily and are securely locked with the counter nut.

7. Backrest mechanism

- 7.1. Function / wear
Check and replace any worn parts, and make sure that moving parts are working correctly.
- 7.2. Attachment / tightening
Check that all screws, knobs and wheels lock properly and that the spring button clips are working correctly.
- 7.3. Plastic plugs / guide bushings
Make sure that guide bushings and plastic plugs are properly secured, and replace worn or damaged parts.
- 7.4. Backrest / replacement / cleaning
Replace the backrest with a new one and wash or replace any covers.
- 7.5. Gas spring lever / function
Check the gas pressure and stability of the gas spring. Ensure that it locks securely and that there is no gradual change in the backrest angle when

loaded. Check and replace damaged wires and sheaths.

8. Armrests

- 8.1. Function / wear
Check and replace any worn parts and make sure that locking mechanisms and moving parts are working correctly.
- 8.2. Plastic plugs / guide bushings
Make sure that guide bushings and plastic plugs are properly secured, and replace worn or damaged parts.
- 8.3. Armrest plates / replacement / cleaning
Replace armrest plates with new ones.
- 8.4. Armrest mechanics / function
Check all welds and that there is no damage to the tube system that may impair or weaken the structure.

9. Accessories

- 9.1. Restoration
Remove any accessories that are not normally installed on the chair and inspect them as detailed below before potentially placing them in storage.
- 9.2. Mechanics
Check all welds and that there is no damage to mechanical parts that may impair or weaken the structure.
- 9.3. Function / wear
Check and replace any worn parts and make sure that locking mechanisms and moving parts are working correctly.
- 9.4. Padded parts
Discard padded parts to prevent cross-infection, and discard or wash covers according to washing instructions.

10. Final inspection

- 10.1. Testing
Test the chair's functionality and that all individual functions, electrical functions and brakes are working correctly. If the chair is to be stored for a period, the chair must be put in sleep mode using the appropriate 9V adapter to save the batteries.

Adaptations may be made only by personnel who have completed Mercado Medic AB's training for service and reconditioning. Parts that are on the list of current combination agreements at www.mercado.se/mercado-dokument may be fitted while retaining Mercado Medic AB's CE marking. Before fitting a part that is not on the list of current combination agreements, the customer's authorised personnel must contact Mercado Medic AB for written approval.

Parts to be evaluated must be sent physically to Mercado Medic AB, either by the customer or the supplier of the part in question. Mercado Medic AB will then contact the supplier of the part in question; if a combination agreement is deemed to be of interest, Mercado Medic AB performs a risk analysis on the part. Once the risk analysis is complete, the customer receives a written opinion.

Chairs that have been modified according to the following must be verified by Mercado Medic AB in order for Mercado Medic AB to retain product liability.

- Padded parts such as seats, backrests, armrests, side supports, trunk supports and headrests can be adapted so long as they do not exceed the existing external dimensions on the product.
- The centre of gravity over lifting devices must be maintained/centred for optimum function.
- Padded parts must be able to withstand the applicable flammability requirements and other environmental requirements.
- Surfaces that are loaded with significant vertical forces must not fall outside the area (base) that is formed by the points of the castor centres.

If these guidelines are met, Mercado Medic AB retains the product liability for its product.

Products that are specially modified by the health care services outside Mercado Medic AB's directive, where the health care services also take over the product liability, can be restored to their original condition. This must be carried out by an authorised technician approved by Mercado Medic AB. Mercado Medic AB then takes back product liability in accordance with the CE marking 93/42 EEC; Medical Devices Directive MDD.

If you have any questions regarding adaptations/special adaptations, contact Ronny Fogelqvist:

Tel. **+46 (0)708 27 96 14**

E-mail ronny.fogelqvist@mercado.se

NOTE! The brake on the chair must always be applied when getting in and out of the chair. The brake must be checked on a regular basis. In case of wear, change the brake rubber. The braking function may be reduced on uneven surfaces.

There are three types of brake:

Brake lever, foot brake and electric brake.

Controls

1. Brake, PLUS base 48 move lever forward
 2. Brake, PLUS base 43 move lever backwards, pedal down
 3. Electric brake, press button
 4. Electric brake, press button
5. Brake lever bracket – to brake the chair even when the armrest is extended in width: loosen the screw on the brake lever bracket using a 6 mm hex key, pull out the bracket, fasten the screw in the next hole and tighten the screw hard using the hex key.

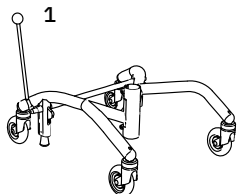

Handbrake

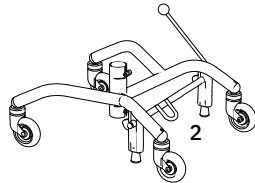

Foot brake

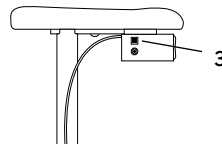

Electric brake (option)

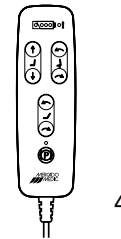

Electric regulator
Handheld controller
(option)

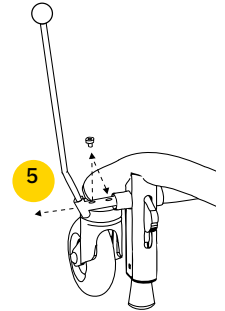

SEAT HEIGHT/LIFTING MECHANISMS

There are two types of lifting mechanisms:

Gas spring and electric. There are standard and low seat heights. Controls for the gas spring can be placed under the seat or armrest. Electric controls are fitted under the armrest as standard.

NOTE! Lightweight people may need help raising and lowering seats controlled by a gas spring.

Controls

1. Seat height. Gas spring – move lever up.
2. Seat height. Electric – move switch up/down.
3. Seat height. Electric – controls in separate box.
Left button = up.
Right button = down.

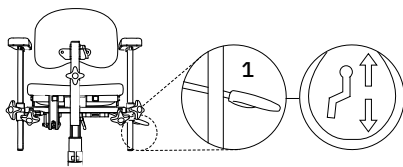

Gas spring lever under the seat

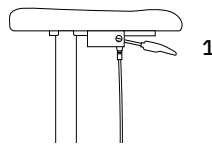

Gas spring lever under
the armrest (option)

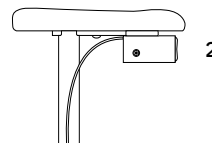

Electric controls under the
armrest

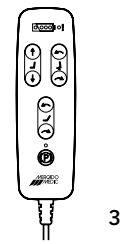

Electric regulator, handheld controller/
Joystick is available as an option.
The separate box is shown in the
picture.

SEAT TILT (OPTION)

There are three types of seat tilt:

Crank, gas spring and electric.

Controls for the gas spring can be placed close to the left rear edge of the seat or under the armrest. Electric controls are fitted under the armrest as standard.

Standard seat tilt range is +15°/- 8°.

Controls

1. Seat tilt. Crank-operated – turn knob
2. Seat tilt. Gas spring – move lever back
3. Seat tilt. Gas spring – move lever up
4. Seat tilt. Electric – move switch up/down.
5. Seat tilt. Electric – controls in separate box.
Left button = forward
Right button = backward.

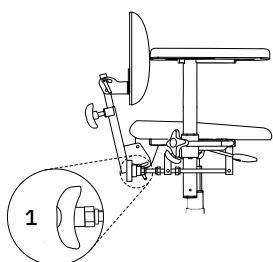

Crank-
operated

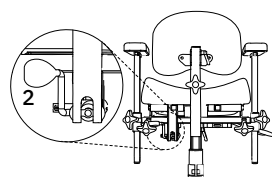

Gas spring lever under the
seat

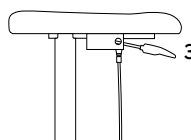

Gas spring lever under the
armrest

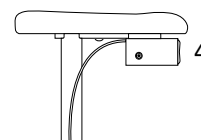

Electrically controlled

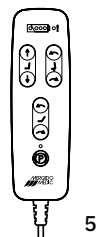

Electric controls,
handheld controller

REVERSED SEAT TILT OR FULL SEAT TILT BACKWARDS (OPTION)

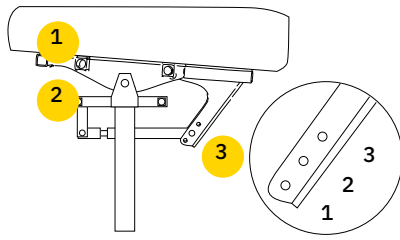

Controls

1. Armrest placed here follows the seat tilt
2. Armrest placed here does not follow the seat tilt
3. There are 3 positions. When position 3 is chosen, the chair must be fitted with a base extender
 1. Forward 15°, back 8° – Standard seat tilt
 2. Forward 8°, back 15° – Reversed seat tilt
 3. Forward 0°, back 23° – Full seat tilt backwards

BACKREST MECHANISM

There are four types of backrest mechanisms:

Standard, Medic, Comfort and Electric.

All are available in a low and high design (illustrated chairs all have a low backrest). All backrest mechanisms have separate controls for height, depth and angle. The Medic model has extended depth adjustment.

Controls

1. Height
2. Backrest mechanism angle
3. Backrest angle
4. Depth
5. Backrest angle. Electric – controls in separate box.

Left button = forward

Right button = backward.

NOTE! Make sure that the Medic backrest mechanism is adjusted in the bracket so the spring button clip locks and the backrest mechanism cannot be pulled out.

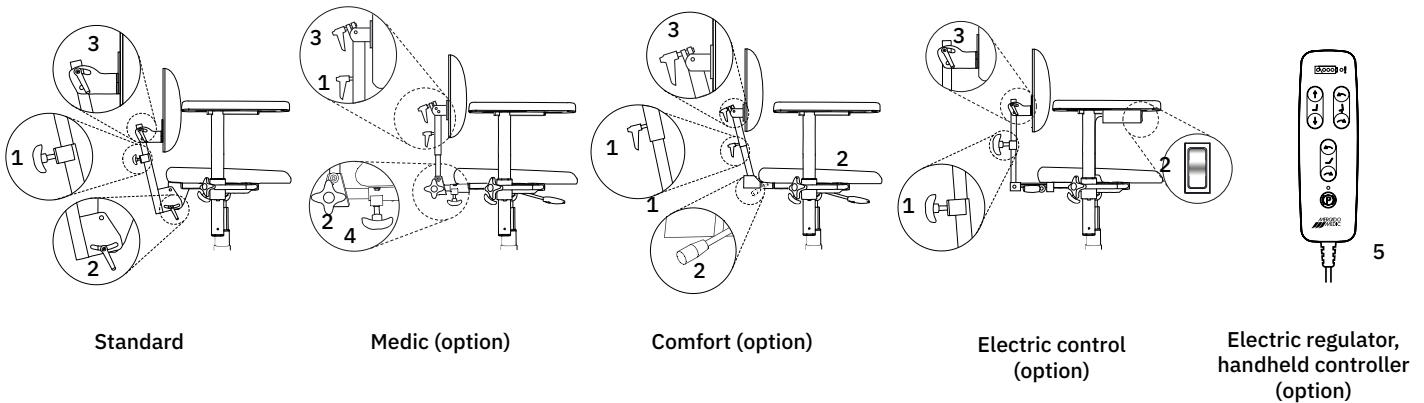

ARMRESTS

Controls

1. Height adjustment
2. Width adjustment
3. Folding

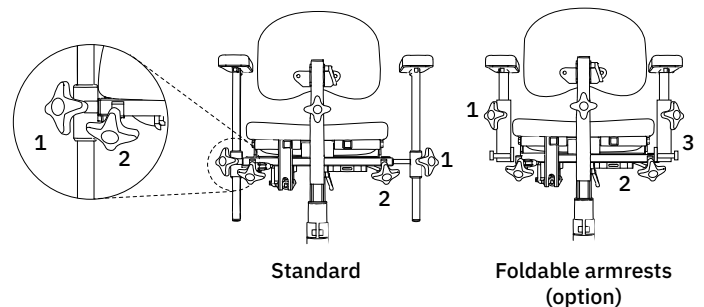

SETTING THE COXIT FLAPS

REAL PLUS Coxit/EL

There are two options for adjusting the coxite flaps. On chairs without seat tilt, the knobs are located under the front edge of the seat. On chairs with seat tilt, the knobs are located under the rear edge of the seat.

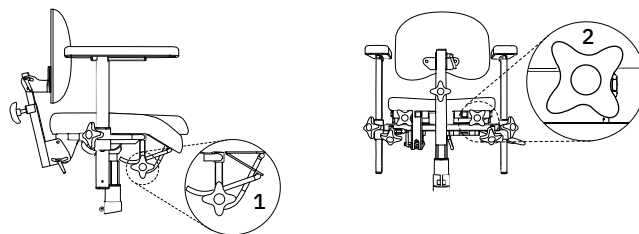

Controls

1. Loosen, set the desired angle and tighten.
2. Turn the knob to lower/raise the flap.

ROTATION RELEASE (OPTION)

PLEASE NOTE! The rotation must be locked in position when getting in and out of the chair. Check that the catch has "clicked" in.

Controls

1. Turn clockwise to disengage, and counterclockwise to lock.

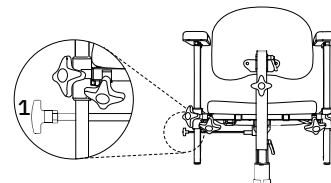

CHARGING

Battery charger 2240-24V (art. no. 804428) must be used to charge the chair. Because the chair is certified as a unit together with the charger, additional tests are required if you want to use a different charger. If using a different charger or different batteries to those which are provided alongside the product by Mercado Medic AB, the CE marking and Mercado Medic AB's product liability will cease to be valid for any cases regarding the battery, charging or other electronics of the chair. The battery should be charged on a daily basis. Fully charging the battery on a daily basis will take 2-6 hours. In order to preserve the battery's service life, it is important that it never becomes fully discharged, as this can damage the battery cells. If the chair is equipped with a handheld controller, the battery level can be determined by checking the indicator lights (1). On a full charge with a high electric lifting mechanism, you can raise the chair fully up/down up to 120 times with a load of 80 kg, or up to 90 times with a load of 150 kg.

How to charge the chair

Connect the jack plug (2) on the charger to the charging outlet (3) (the charging outlet can be placed under the chair's seat or armrest, depending on agreement or preference). Then plug the charger into a wall socket. The LED on the charger will indicate that charging is under way. When the LED changes colour from orange to green, the battery is fully charged.

None of the electrical functions will work while the chair is charging. The chair must be charged in a safe manner. For this reason, choose a wall socket that is easily accessible to plug the charger into. The charger's cable is 1.8 m and must not be extended. In case of emergency, disconnect the chair from the mains by unplugging the charger from the wall socket. Do not sit in the chair while it is charging.

Connecting and disconnecting the battery

During longer periods of storage, the battery is automatically disconnected after seven days. The battery can also be forced into a disconnected state by connecting a 9V power supply (art. no. 804823) to the charging outlet and waiting at least five seconds before disconnecting the power supply. If the handheld controller is used, all of the indicator lights will flash when the battery is disconnected and the power supply can then be disconnected. When the battery is disconnected, it must be charged every four months in order to retain its functionality. If these charging instructions are followed, the battery will maintain sufficient capacity for four years. To reconnect the battery to the system again, connect the battery charger to the charging outlet and wall socket. Wait at least five seconds before disconnecting the battery charger. The battery is now activated again and the system is ready for use. We recommend leaving the charger in place and fully charging the battery after the product has been stored with the battery in a disconnected state.

Before first use

This product is delivered by Mercado Medic AB with the battery disconnected. Before first use, the battery must be connected to the system. This is done by connecting the battery charger to the charging outlet and the wall socket. Keep the battery charger connected until the battery is fully charged. This will be indicated by a green light on the charger's LED. If you are using the handheld controller, this will also be indicated by the three green battery LEDs on the controller, which will start to flash at the same time. The battery may also need to be charged when it has been disconnected, as a certain degree of self-discharge always occurs for batteries.

NOTE!

It is particularly important to charge the battery on chairs with electric brakes, electric tilt mechanisms and electric backrests because these functions require a high battery capacity to be maintained. Guarantee these functions by recharging the battery once a day. The battery may only be replaced by personnel authorised by Mercado Medic AB. See assembly instructions, Battery Replacement.

Troubleshooting for electrical functions on your chair

There are no movements at all:

- The battery might need to be charged. See the instructions above.
- The duty cycle may have been exceeded. If the duration of use of the electrical functions is approaching the limit value, the warning light on the handheld controller starts flashing (the ! symbol). If the duration of use exceeds the limit value, the electrical functions are switched off and cannot be used again until the system has recharged. If the user presses a button before the system has recharged, the warning light will flash.
- An internal error may have been detected by the system, which then shuts down one or all of the function channels and switches on a warning light on the handheld controller. The system will be reset automatically after 10 seconds. If the error has been resolved, then all channels will be unlocked and the warning light will be switched off.
- The button lock may be enabled. To enable or disable the button lock for a function, press and hold both of the directional buttons of the relevant function for at least three seconds.

The electrical functions on the chair are slow:

- The battery needs to be charged. See the instructions above.

If none of the above measures are able to resolve the problem, servicing may be required. Please contact your dealer or get in touch with Mercado Medic AB. You will find our contact details on the last page of this manual.

Emergency stop

If, for whatever reason, the system does not interrupt a movement after the corresponding function button has been released, the movement can be interrupted by pressing any of the other buttons on the handheld controller. If a fixed control unit is being used instead of a handheld controller, the same emergency stop function can be initiated by pressing the button for movement in another direction.

- A. Charging is required
- B. Battery level
- C. Warning light (internal error/button lock)

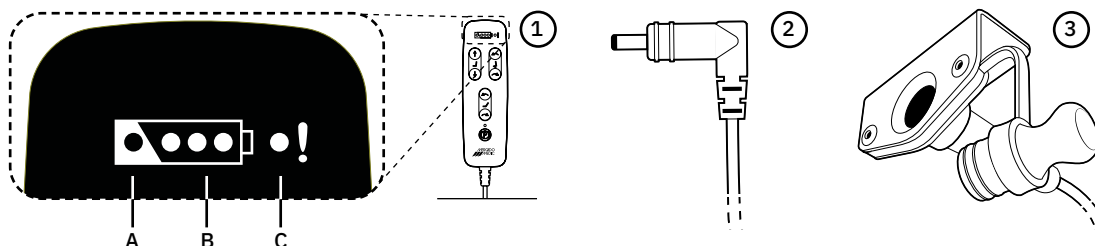

CONTACT MERCADO

Head office

Tryffelslingan 14, SE-181 57 Lidingö

Postal address

Box 1074, SE-181 22 Lidingö

The switchboard is open: Mon-Fri 08.00-16.30 (CET/CEST)

Tel: +46 (0)8-555 143 00

Fax: +46 (0)8-555 143 99

E-mail: info@mercado.se

Service and technical support

Box 1074, SE-181 22 Lidingö

Telephone hours for the service line: Mon-Fri

08.00-12.00 and 13.00-16.00 (CET/CEST)

Tel: +46 (0)8-555 143 08

Fax: +46 (0)8-555 143 99

Mobile phone: +46 (0)70-550 63 98
+46 (0)70-894 63 68

E-mail: service@mercado.se

[Space for product label with serial number.]



Mercado Medic AB
Tryffelslingan 14
SE-181 57 Lidingö

Telephone & Fax
Tel. +46 (0)8-555 143 00
Fax +46 (0)8-555 143 99

E-mail & Internet
E-mail info@mercado.se
Internet www.mercado.se