



⊕ REAL[®] 6100 PLUS



INSTRUCTIONS FOR USE AND CARE REAL 6100 PLUS

Article No.
Changed 121113
Valid from 130517

REAL 6100 PLUS is an electrically powered indoor wheelchair for people with various disabilities. The REAL[®] chair as specified below model is CE certified in accordance with the MPA statutes of medical devices LVFs 2003:11.

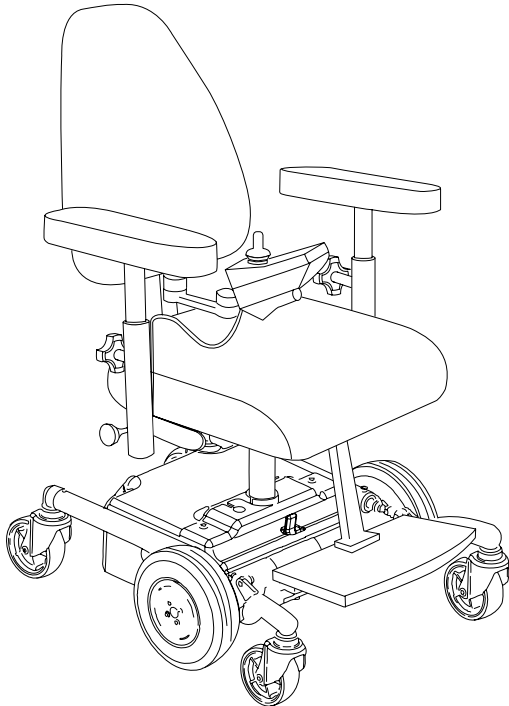

INDEX

TECHNICAL INFO	PAGE 3
USER GUIDE	PAGE 5
CONTROL BOX SHARK	PAGE 7
CONTROL BOX DX 2-REM550	PAGE 8
CHARGING	PAGE 9
PROGRAMMING DIAGRAM OF THE ELECTRONICS	PAGE 11
INDIVIDUAL CUTSTOMIZATION	PAGE 12

GET ACQUAINTED WITH YOUR REAL 5100/6100 – PLEASE READ THESE OPERATING AND MAINTENANCE INSTRUCTIONS AND THE USER GUIDE BEFORE USING THE WHEEL CHAIR.

PRE-USE INSPECTION CHECKLIST

- All knobs and locking wheels shall be tightened on the chair before use.
- The leg support may not be adjusted so that it touches the floor or the ground at any time.
- If the REAL 6100 is equipped with a belt or a harness of any kind it may not hang loosely on the chair but used as intended or taken off.
- Make sure the foldable armrests are in an upright position before driving the chair.
- Fold down the footplate.
- Attach the backrest.

PRE-USE INSPECTION CHECKLIST CONTROLLER

- Turn on the main switch.
- Make sure the battery level indicator should not be down at the red mark.
- Make sure the controller does not display any errors.



Mercado Medic AB
Tryffelslingan 14
181 57 Lidingö
Sweden

Telefon & Fax
Tel +46 8 555 143 00
Fax +46 8 555 143 99

Email & Internet
Email info@mercado.se
Internet www.mercado.se

IMPORTANT INFORMATION AND CLASS

The REAL 6100 PLUS chair has exchangeable components, accessories and functions that can be adjusted to suit individual needs. The chair should only be used by the person and for the purpose for which it was originally intended. The chair is designed for indoor use and should not be exposed to water, other fluids or chemicals nor should it be exposed to high temperatures intensive sunlight or similar. The chair may not be equipped with other accessories or components than those approved by Mercado Medic. Repairs and other technical adjustments may only be carried out by personnel authorised by Mercado Medic. Please read through these instructions carefully before using your chair.

- REAL 6100 PLUS is classified as A and is intended for indoor use only.
- Max users weight: 135 kg. If you want to adjust for heavier users – contact Mercado Medic UK.
- REAL 6100 PLUS is tested and approved according to the EMC-directive.
- Mobile Phones do not affect the manoeuvring of REAL 6100 PLUS.
- REAL 6100 PLUS may not be equipped with other accessories or components other than those authorised by Mercado Medic AB.
- Repairs or other engineering work must be performed by personnel authorised by Mercado Medic AB.
- Chairs with adjustable seat angle should be in fixed position when sitting in or rising up from the chair.
- REAL 6100 PLUS shall not be operated when the seat height is in the raised position.

STORAGE, CLEANING AND MAINTENANCE

Keep the chair in a dry, room temperature environment. Check battery level prior to use. If the chair is to be stored for longer than a month the battery terminals should be disconnected. The chair is intended for indoor use and should not be flushed with water, other liquids or chemicals. The chair can be cleaned/wiped clean with disinfectants. Do not expose the chair to high heat or prolonged/intense sunlight or other radiation.

The chair should be wiped clean and kept free of dust and dirt and the upholstery cleaned with foam upholstery cleaner. Remove loose dirt from the fabric.

- Apply a thin layer of foam and rub it into the fabric evenly with a damp cloth.
- Wipe dry with a clean, damp cloth.

- Vacuum well when dry.

The seat, backrest and other padded parts are, for functional purposes, not made of impermeable materials. For hygienic reasons, when the upholstery is changed, the seat and padding material should be replaced.

The electronic lifting device should be checked regularly for dust and dirt. Put the seat into its highest position. Clean with a cloth. (Water or solvents may not be used).

Then lubricate the cylinder with a thin layer of Teflon- or siliconbased grease, which does not become overviscous like greases based on mineral oils.

TECHNICAL DATA

TECHNICAL DATA

Max user weight	135 kg
Top speed	4,5 km/h
Turning space 180°	870 mm
Driving wheel	Both center wheels
Driving time per charge	approx. 15 km
Obstacle ability	40 mm
Weight	76 kg incl. batt.
Charging time	approx. 6-8 hours
Charger tested and approved by Mercado Medic AB	Mentzer 3A Easy Buddy 4A
Batteries tested and approved by Mercado Medic AB	Sonnenschein 2pcs 12V 25 Ah

STANDARD MEASUREMENTS

Total width	570 mm
Length	795 mm
Wheel front/back	Ø 125 mm
Driving wheel	Ø 210 mm
Seat height	480-760, 410-610 mm*
Leg support length	370-530 mm
Seat width	290-480 mm
Seat depth	320-480 mm
Seattilt	-15° +8°, -8° +15°, 0° +23°
Back support height	330-430 mm
Back support angle	-15-+45°

*with the ability to adjust down to a maximum of 3 cm.

PROGRAMMING DEVICE

Selection of programmable functions:

- Forward speed
- Forward acceleration
- Forward deceleration
- Reverse speed
- Reverse acceleration
- Reverse deceleration
- Turning speed
- Turning acceleration
- Turning deceleration
- Joystick sensitivity
- Reversed joystick function
- Use of external joystick

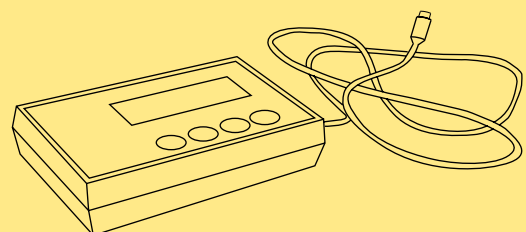

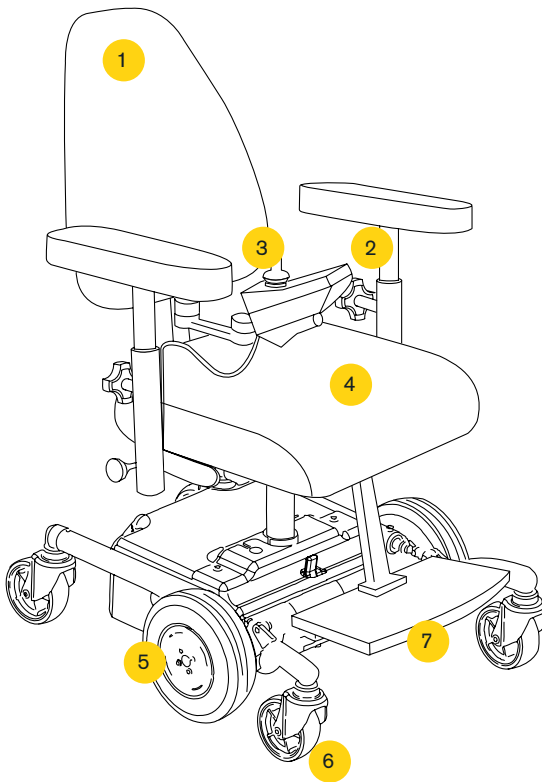

- 1. Backrest
- 2. Armrest
- 3. Controller
- 4. Seat
- 5. Drive wheel
- 6. Individual wheel suspension
- 7. Footplate

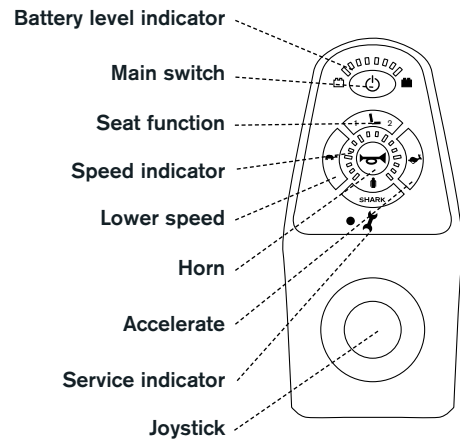

Control box SHARK

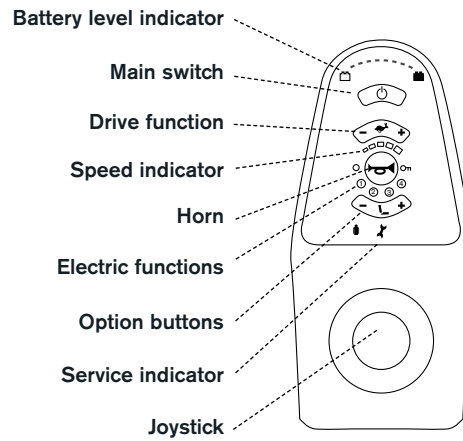

Control box DX 2-REM421

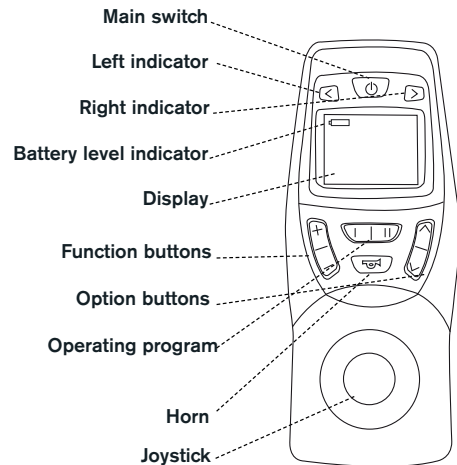

Control box DX 2-REM 550

ARMREST

The user can adjust the armrests height and width. If the chair comes with folding armrests, these can be folded down.

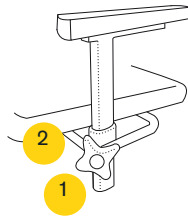

Armrest

CONTROLS

1. Height adjustment. Turn to lower/raise the armrest
2. Width adjustment
3. Folding mechanism

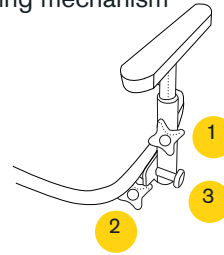

Foldable armrest

ATTACHING AND ADJUSTING THE BACKREST

Lower the backrest (1) into the backrest mechanism (2) while you hold the snap lock (3). Adjust to the desired height. Lock the backrest by tightening the knob (4).

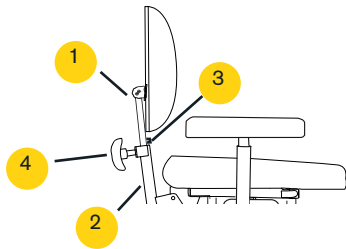

BACKREST

THERE ARE FOUR TYPES OF BACKREST MECHANISMS:

Standard, Medic, Comfort and Electric.

All are available as low-and high-performance (all illustrated chairs have low mechanism).

All backrest mechanisms have separate controls for height, depth and angle. The Medic model is adjustable in depth. Backrest mechanism can be electrically operated as an option, see the control panel.

CONTROLS

1. Height adjustment
2. Angle adjustment of backrest mechanism
3. Angle adjustment of backrest plate
4. depth adjustment
5. Electric controls – see the section for control box.
6. **NOTE!** Ensure that the Medic backrest fits in the bracket so that snap locks and the backrest cannot be pulled out.

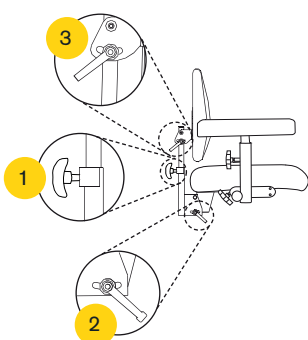

Standard

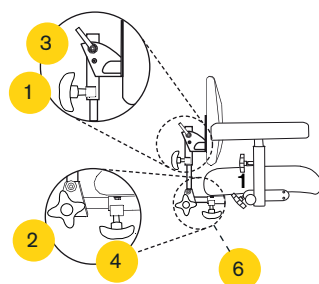

Medic (Option)

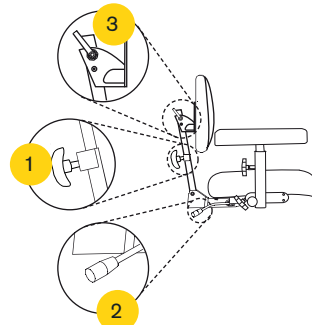

Comfort (Option)



Electric

TRANSPORTATION SERVICE

Users must not be seated in the chair when transporting the REAL 6100 PLUS. Users must move over to the dedicated vehicle seat. The chair must be equipped with transport loops and must be anchored to the vehicle using straps. Transport loops are accessories that can be ordered separately, article number 802210.

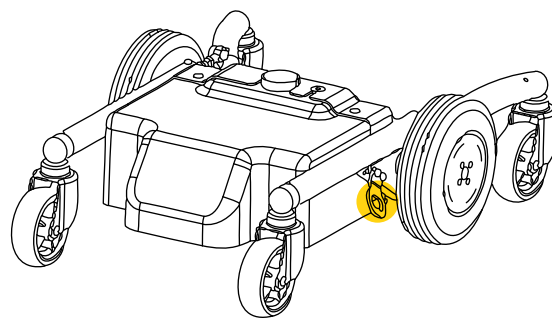

SEAT TILT

THERE ARE THREE TYPES OF SEAT TILTS:

Gas spring, crank control and electric tilt. The gas spring lever is located at the rear right side under the seat (1) and is adjusted by moving the lever slowly forward. The controls are alternatively under one of the armrests (2). Crank operated tilt is adjusted using the crank from the rear (3). The range of the tilt can be reduced using attached nuts (4). Electric seat tilt is controlled from the controller, see the controller section.

SEAT TILT MECHANISMS

1. Gas spring under armrest
2. Gas spring under seat
3. Crank control under seat
4. Electric – see control box section.

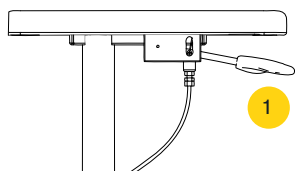

Gas spring

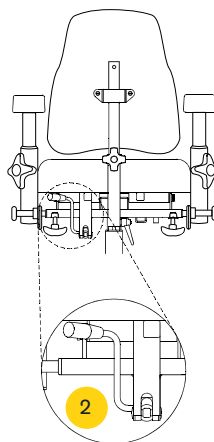

2

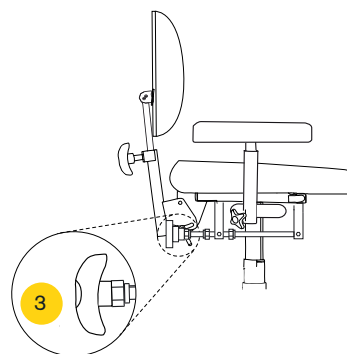

Crank control

4

Electric

REVERSE TILT OR ALL TILT BACKWARDS (OPTIONAL)

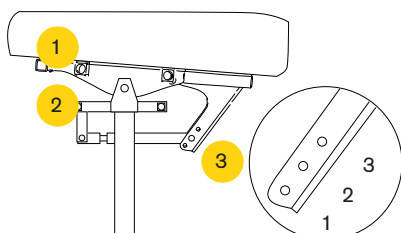

CONTROLS

1. Armrest attached here move with the seat tilt
2. Armrest attached here do not move with the seat tilt
3. There are 3 positions. **When selecting position 3, the seat must be equipped with base extensions.**
 1. Front 15°, back 8° – standard seat tilt
 2. Front 8°, back 15° – reversed seat tilt
 3. Front 0°, back 23° – all seat tilt backwards

ADJUSTING THE CONTROLLER POSITION

The controller can be adjusted for depth and sideways position. To adjust the depth, undo screw (1) with a 5 mm Allen key. Move the controller arm to the required position (out of three possible) and reattach the screw. The controller can also be moved sideways to either the inside or the outside of the armrest. The control arm is jointed at two points.

This allows the control box to be moved horizontally and sideways without the use of tools. Push the controller into the desired position and it locks into position by itself. The controller can be placed on either side of the chair.

WITH PARALLELOGRAM

The magnetic attachment allows the controller to be positioned parallel to the arm rest. Adjust the position of the screw (1) then lock the screw.

Adjust the control box to the desired position, release.

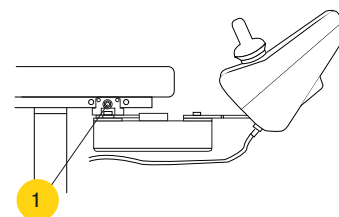
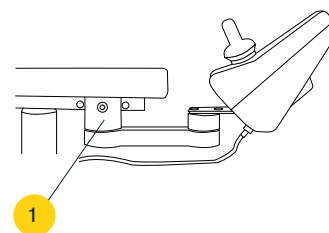

FOOTPLATE

The footplate has a height and an angle adjustment. To adjust the height of the footplate: loosen screw (1). Adjust the foot-plate to the required height and tighten the screw. Note: ensure that the screw enters one of the inner tube's countersunk depressions. The angle of the footplate is adjusted using screw (3) with a 5 mm Allen key. To lower, turn the screw clockwise; to raise, turn the screw anti-clockwise. The leg position can be adjusted to four positions. Loosen and remove screw (2) with a 5 mm Allen key. Set the required angle, return the screw into the relevant hole and tighten.

Calf/heel support and base plate with depth 100 mm are available as options. Also with depth, width, height and angle adjustment.

CONTROLS

1. Height
2. Angle – legrest
3. Angel – footplate

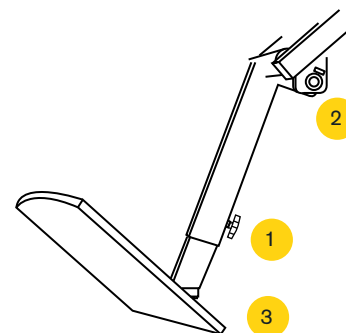

BRAKE RELEASE

Releasing the brake enables the chair to be moved manually. To disengage the brakes press the switch away from you (1), upwards in the picture on the right. To apply the brakes again, push the controls back to the original position. If the chair is disengaged when it is on, the panel will display an alarm which means that the chair is not possible to use. As soon as the brake is engaged, the alarm is off and the chair is again possible to use.

Note! The chair must never be transported with the brakes disengaged.

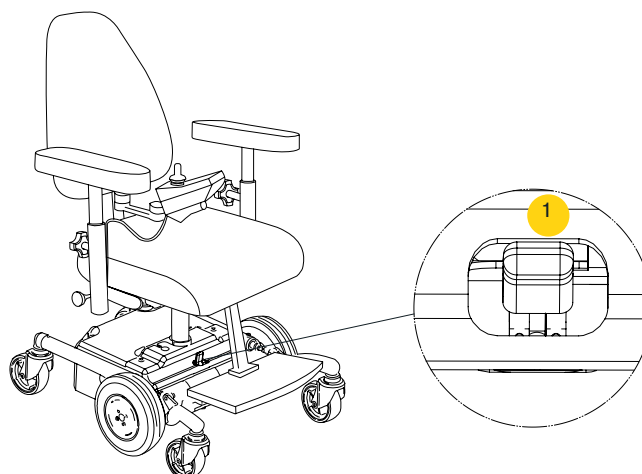

CONTROLLER SHARK

MANEUVER OPERATION

Press the main switch (1). Check the battery level (4). The battery level should not be down at the red mark (see “Charge”). Make sure the service indicator (9) is not lit.

DRIVING

Before driving check that the seat function indicator (6) is not lit. When driving the chair for the first time, start with a low speed and gradually increase the speed until you reach a comfortable cruising speed. To reduce speed press the button with a turtle (2), to increase speed press the button with a rabbit (3). To fine-tune the speed, hold switch (2 alt. 3) to the desired speed is displayed on the speed indicator (7).

SEAT UNIT

To select the seat control, press the button (6). Pressing once lights function 1, pressing twice switches mode to function 2. Seat height is always operated by function 1. To raise or lower the seat press the joystick forward alt backwards. Function is switched off if the seat has no further power functions. To return to run mode press the button (6) again.

If the chair’s electrical functions are not used in five minutes, the controller is automatically turned off to save battery. To boot the electronics press the main switch (1) or push the joystick (5). The time interval for automatic shut-off is adjustable. Horn: press the button (8).

LOCK THE CONTROLLER, SHARK

When the controller is turned on, hold the power button (1) for 4 seconds. The controller is turned off. After 4 seconds, all LEDs light up for a moment and a the horn will sound. After that, turn the controller on and it is now locked.

UNLOCK THE CONTROLLER, SHARK

When the controller is locked. Press the power button to turn on the control box. All LED lights up quickly. Battery indicator LED (8) will then light up and count down slowly from right to left. Press the “Horn” button (8) twice before the battery indicators LED is completely related. You have about 10 seconds. After that, the current battery level and your REAL 6100 is ready for use.

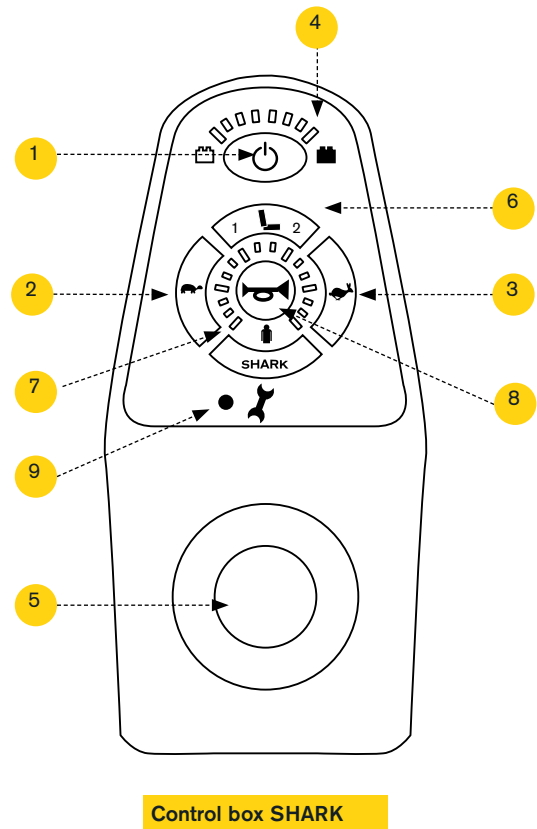

MANOEUVRE OPERATION

Press the main switch (1). Check the battery level (4). The battery should not be down at the red mark. (See “charging”).

Driving: make sure the display (3) shows one of the driving programs 1 to 5. Press function buttons (2) until any of these numbers appear. Set the program speed with function buttons (6). Push the joystick (5) straight forward to drive forwards and diagonally left/right-forward to turn. The chair can be turned around by moving the joystick (5) straight left/right.

To reverse, pull the joystick (5) backwards.

Horn: press the button (8).

SEAT UNIT OPERATION

To raise/lower the seat unit or to operate electric tilt, backrest angle or angle of footplate. Press the Option key (7) until a chair appears. The electrical functions that are available on the chair are displayed (one function visible at a time). Press the function button (6) to toggle between the symbols or move the joystick from side to side. The electric function that is active is blue in the display (3). Move the joystick forward/backward alt left/right to operate the different functions. The symbol on the display switches to green when adjusting.

Adjust the seat height: move the joystick (5) forward to raise the seat, and down to lower it. Adjust the seat tilt: move the joystick (5) forward to tilt the seat forward, and back to tilt it backward. Adjust the angle of the backrest: move the joystick (5) forward to tilt the backrest forward, and back to tilt it backwards.

OPERATING THE ELECTRICAL FOOTPLATE OPTION

The footplate has height and angle adjustment. Press the option button (7) until a chair appears. Press the function button (6) or move the joystick (5) left/ right to highlight the function “electrical footplate” which is divided into right and left. Move the joystick (5) forward to extend and tilt the footplate or backward to retract the footplate and move it backward.

To adjust the left footplate only, navigate to No. 1 and move the joystick (5) forward to tilt the footplate up or move it backward to tilt it down. To merely extend/ shorten the footplate on the left side navigate to No. 2 and move the joystick (5) forward to extend the footplate and back to make it go back. To adjust the

right footplate only navigate to No 3 (see No. 1) and No. 4 for vertical adjustment (as explained in # 2).

When the chair’s electrical functions are not used in five minutes it will turn off automatically to save battery. To boot the electronics press any key. The time interval for automatic shut-off is adjustable.

IN ORDER TO LOCK THE CONTROLLER, DX 2

When the controller is turned on, hold the power button (1) for 4 seconds. Lock will be displayed. The control box is turned off.

TO UNLOCK THE CONTROL BOX DX 2

Press the Power button (1).

A lock appears in the display.

Push the horn (8) twice within 10 seconds.

The control box is started.

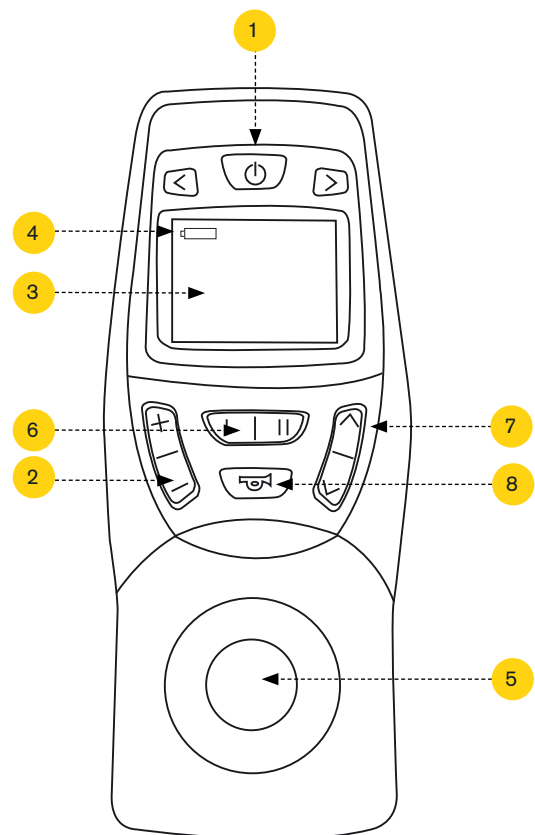

Controlbox DX 2-REM550

CHARGING

LED 1 On	Connected to mains
LED 2 On	Charging commences. LED flashes, when battery is charged 90%
LED 3 On	Battery charged, charger is in float charge mode
LED 4 On	Battery is connected in reverse polarity. Disconnect the mains supply immediately, change the battery connection and repeat the start procedure.

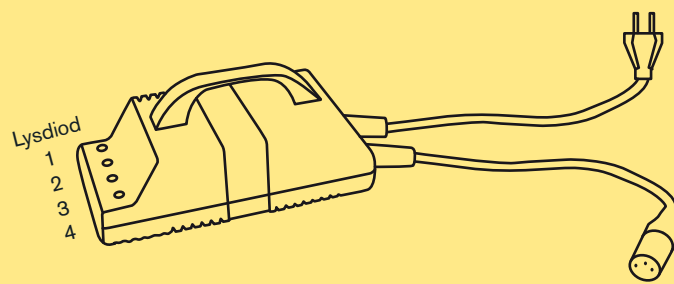

Charger 6100 series 3/4 artno. 801965

MAINTENANCE, CHARGE THE CHAIR EVERY MONTH OR CONTINUOUSLY

When only the red lights appear on the battery indicator (4, in the illustration at the top of the page), this means that the chair is running on reserve power. The batteries should be recharged since only 10 percent of the battery's capacity remains. If the chair continues to be used, the red lights will start to flash to give a further reminder of the need for recharging. To charge, make sure that the chair is switched off. Insert the charge plug (1) into the charge socket (2) on the front of the controller. Then connect the charger's mains plug (3) to a wall socket. A yellow light (4) comes on when the battery is charging. When light (4) turns off, the battery is charged 90% of its capacity and can be used. To increase the durability of the battery it is recommended to wait until light (5) is on.

When exchanging battery (brand: Sonnenschein, type: Dryfit A500 A512 12V 25 Ah), make sure to connect the cable marked with a plus sign to the positive pole on the battery. The negative cable should be connected to the negative pole.

GUIDELINES WHEN HANDLING BATTERIES:

- Do not ever short-circuit the battery.
- Do not throw it on a fire.
- Avoid heavy bumps to the battery.
- If exposed to battery acid, rinse immediately with water for at least 15 minutes then contact a doctor.
- Used batteries must be left at a recycling station.

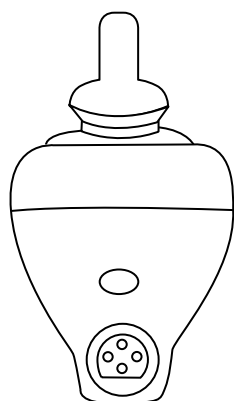

2

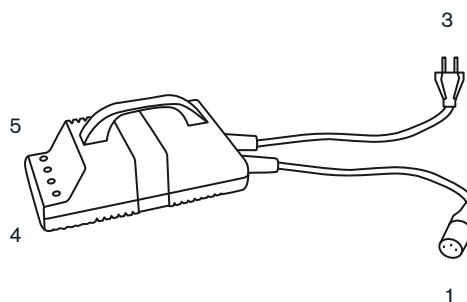

1

SAFETY INSTRUCTIONS

The chargers are especially designed to charge maintenance free lead acid batteries. The charger housing should only be opened and maintained by authorized personnel. Unqualified opening may cause damage to the charger and will void the guarantee. Operation with an opened housing is strictly prohibited. Only a qualified technician is allowed to replace the fuse. The charger should only be operated if sufficient cooling is assured. The chargers should only be operated in closed rooms and must be protected against moisture.

PUTTING INTO OPERATION

Compare the rated voltage of the type plate of the charger with the rated voltage of the battery. If identical connect the battery with the correct polarity. Red cable to plus (+) terminal, black cable to minus (-) terminal of the battery. Connect the mains supply. When the polarity is correct a LED 1 and LED 3 ignites. The LED 3 will turn off shortly and the LED 2 ignites. The battery will now be charged with the rated current. If connected with reverse polarity, the LED 4 illuminates. In this case disconnect the mains supply immediately, charge the battery connection and repeat the start procedure after 30-60 seconds. If LED 4 and LED 3 illuminates after connecting battery and mains, the battery is not connected or the battery wiring is damaged.

SPECIAL INSTRUCTIONS TO AVOID SPARKS:

- Connect mains supply without battery connection.
- Disconnect mains after a short period of time.
- Connect battery with correct polarity.
- Connect mains supply.

RECOMMENDATIONS FOR CHARGING SEALED LEAD ACID BATTERIES:

Charge/Discharge

- Charge 12 hours prior to initial use.
- Charge after each discharge even after partly discharge.
- Never store a discharged battery.
- A completely discharged battery must be charged for min. 16 hours.

- If the charging time is below 16 hours for more than 3 times then charge one time for 24 hours to equalize the poor charging.
- The ambient charging temperature should range between 10°C and 30°.

BEFORE LONGER STORAGE PERIODS (2 POSSIBILITIES):

A Disconnect the battery from the charger and store it fully charged. Before storage periods exceeding 3 months charge the battery for min. 36 hours.

B You can leave the battery on charge for an unlimited time (maintenance charge). It is recommended to store the battery in a cool place.

HIGH AMBIENT TEMPERATURES

Charging in temperatures above 30°C is not recommended. Your charger is adjusted with a charging voltage valid for 20°C.

LOW AMBIENT TEMPERATURES

Charging below 10°C is not recommended. In low temperatures the available capacity is reduced.

DEEP DISCHARGE

Try to avoid deep discharges. If a deep discharge occurred, charge the battery as soon as possible for 24 hours.

GENERAL

The charger is designed in the primary switch mode technology. The technology provides a constant DC voltage which guarantees for a long lifetime for maintenance free sealed lead acid batteries. A holding device for wall mounting will be found on the back of the charger.

WIRING DIAGRAM FOR CONNECTION OF OTHER CHARGERS

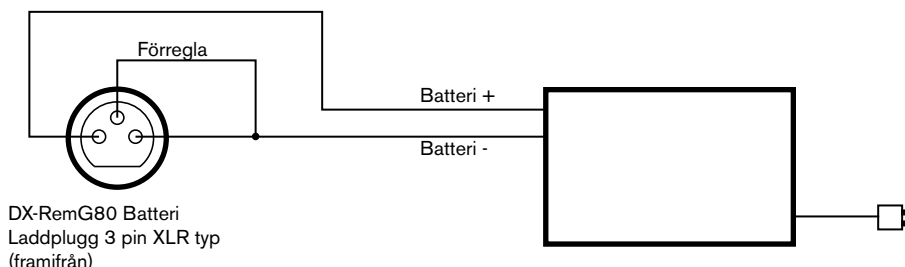

PROGRAMMING DIAGRAM OF THE ELECTRONICS

STANDARD PROGRAM

	DX2	PROG. 2	PROG. 3	SHARK	USER SETTINGS			
	PROG. 1			PROG. 1	PROG. 1	PROG. 2	PROG. 3	PROG. 4
Max forward speed	25 %	45 %	75 %	75 %				
Forward acceleration	20 %	25 %	30 %	30 %				
Braking, forward	35 %	40 %	50 %	75 %				
Max reverse speed	20 %	25 %	50 %	50 %				
Reverse Acceleration	20 %	20 %	25 %	25 %				
Reverse brake	35 %	35 %	50 %	50 %				
Max turning speed	15 %	20 %	45 %	40 %				
Turn acceleration	20 %	20 %	25 %	30 %				
Turn braking	35 %	40 %	55 %	55 %				
Joystick sensitivity	50 %	50 %	50 %	40 %				
Grip / Traction	100 %	100 %	80 %	80 %				

* MUST NOT BE INCREASED. INCREASE AT YOUR OWN RISK.

GUIDELINES FOR INDIVIDUAL CUSTOMIZATION OF MERCADO MEDICS PRODUCTS

Customizations shall only be done by authorized personnel who have received Mercado Medic training program for service and reconditioning.

Articles that are on the list over current combination agreements are allowed to be fitted with maintained CE-marking. If an article wants to be fitted that is not on this list must authorized personnel contact Mercado Medic and ask for a written approval.

Article to be approved must physically be sent to Mercado Medic for evaluation. Mercado Medic will then contact the supplier of the article in order to sign a mutual combination agreement. In that process Mercado Medic conducts a risk analysis for the article in combination with Mercado Medics product. When the risk analysis is conducted the customer/supplier receives a written notion.

Chairs that have undergone changes, as described below, shall be verified by Mercado Medic to maintain product liability.

- Upholstered parts such as seats, backrests, armrests, side supports and neckrests can be customized as it do not exceed the original product measurements or centre of gravity.
- Center of gravity in relation to the actuator must be maintained.
- Upholstered parts shall meet current fire and environmental requirements.
- Surfaces put under considerable load must not be outside the square formed by the wheels on the base.

If these guidelines are fulfilled Mercado Medic will keep the product responsibility (CE).

Special customization done by the healthcare beyond Mercado Medic guidelines overtake the responsibility for the product in its form, but also how it is put back in its original form. This must be done by an authorized technician approved by Mercado Medic. Mercado Medic then overtake the product responsibility according CE93/42EEC; Medical Products Directive MDD.

For questions regarding adjustments/customizations, contact Andreas Teske.

Phone [08-555 143 19](tel:08-55514319)

Email andreas.teske@mercado.se



Mercado Medic AB
Tryffelslingan 14
181 57 Lidingö
Sweden

Telefon & Fax
Tel +46 8 555 143 00
Fax +46 8 555 143 99

Email & Internet
Email info@mercado.se
Internet www.mercado.se